

REVISED INITIAL ENVIRONMENTAL EXAMINATION (IEE) of  
DMA 601, 605, 607 & 608

DISTRIBUTION NETWORK IMPROVEMENT PACKAGE NO. ICB 02.7  
DHAKA ENVIRONMENTALLY SUSTAINABLE WATER SUPPLY PROJECT  
(BAN: 3051)

**February 2017**

Updated by Management and Supervision Consultants (MSC) for ICB 02.7 of Dhaka Environmentally Sustainable Water Supply Project (DESWSP)

Prepared by the Dhaka Water Supply and Sewerage Authority (DWASA) Government of Bangladesh (GoB) for the Asian Development Bank (ADB)

## CURRENCY EQUIVALENTS

(as of 1<sup>st</sup> April 2016)

Currency unit	–	Taka (Tk)
Tk.1.00	=	\$0.01283
\$1.00	=	Tk. 77.95

## ABBREVIATIONS

ADB	–	Asian Development Bank
AP	–	affected person
DMA	–	district metering area
EMP	–	environmental management plan
GRC	–	grievance redressal committee
GRM	–	grievance redress Mechanism
IEE	–	initial environmental examination
NRW	–	non-revenue water
O&M	–	operations and maintenance
PMU	–	project management unit
REA	–	rapid environmental assessment
SPS	–	Safeguard Policy Statement
HDD		Horizontal Directional Drilling

## WEIGHTS AND MEASURES

km	–	kilometer
km <sup>2</sup>	–	square kilometer
m <sup>2</sup>	–	square meter
mm	–	millimeter
m <sup>3</sup> /day	–	cubic meter per day

## NOTE

In this report, "\$" refers to US dollars.

This initial environmental examination is a document of the borrower. The views expressed herein do not necessarily represent those of ADB's Board of Directors, Management, or staff, and may be preliminary in nature.

In preparing any country program or strategy, financing any project, or by making any designation of or reference to a particular territory or geographic area in this document, ADB does not intend to make any judgments as to the legal or other status of any territory or area.

# CONTENTS

<b>EXECUTIVE SUMMARY</b>	<b>I</b>
<b>I. INTRODUCTION</b>	<b>1</b>
A. Purpose of the Report	1
<b>II. POLICY, LEGAL, AND ADMINISTRATIVE FRAMEWORK</b>	<b>2</b>
A. ADB Policy	2
B. National Laws	3
<b>III. DESCRIPTION OF THE PROJECT</b>	<b>3</b>
A. Existing Condition and Need for the Project	3
B. Proposed Components	4
C. Implementation Schedule	7
<b>IV. DESCRIPTION OF THE ENVIRONMENT</b>	<b>7</b>
A. Methodology Used for the Baseline Study	7
B. Physical Characteristics	7
C. Ecological Resources	8
D. Economic Development	9
E. Social and Cultural Resources	12
F. Site Specific Existing Condition of 16 DMAs in the Project Area	13
<b>V. ANTICIPATED IMPACTS AND MITIGATION MEASURES</b>	<b>14</b>
A. Magnitude and Significance of Impacts	14
B. Planning and Design Phase	15
C. Construction Phase	17
D. Operations and Maintenance Phase	22
E. Mitigation Measures	24
F. Cumulative Impact Assessment	24
<b>VI. INFORMATION DISCLOSURE, CONSULTATION, AND PARTICIPATION</b>	<b>25</b>
A. Public Consultation Conducted (Planning and Design Stage)	25
B. Future Consultation and Disclosure	27
C. Involvement of NGOs, CBOs and Women's Organizations	27
<b>VII. GRIEVANCE REDRESS MECHANISM</b>	<b>28</b>
<b>VIII. ENVIRONMENTAL MANAGEMENT PLAN</b>	<b>30</b>
A. Implementation Arrangement	31
B. Capacity Building	34
C. Environmental Management Action Plan	35
D. Reporting	57
E. Environmental Costs	57
<b>IX. CONCLUSION AND RECOMMENDATION</b>	<b>60</b>

<b>APPENDIX 1: ADB REA CHECKLIST</b>	<b>61</b>
<b>APPENDIX 2: DETAILED COMPONENTS OF DMA 601, 605, 607 &amp; 608 OF PACKAGE NO. ICB 2.7</b>	<b>64</b>
<b>APPENDIX 3: RECORDS OF PROJECT INFORMATION DISCLOSURE MEETING DMA 601</b>	<b>67</b>
<b>APPENDIX 4: SAMPLE GRIEVANCE REDRESS FORM</b>	<b>69</b>
<b>APPENDIX 5: ENVIRONMENTAL REPORTING</b>	<b>70</b>
A. Suggested outline for the Environmental Monitoring Report	70
<b>APPENDIX 6: SITE ENVIRONMENTAL PLAN OF DMA 601, 605, 607 &amp; 608</b>	<b>75</b>
A. Site Environmental Plan of DMA-601	76
B. Site Environmental Plan of DMA-605	77
C. Site Environmental Plan of DMA-607	78
D. Site Environmental Plan of DMA-608	79
<b>APPENDIX 7: IMPLIMENTATION PLAN OF PACKAGE ICB 02.7</b>	<b>80</b>
<b>APPENDIX 8: WORKSHOP ON EMP IMPLEMENTATION OF ICB 02.7</b>	<b>81</b>
<b>APPENDIX 9: ASBESTOS CEMENT PIPE HANDLING PROTOCOL</b>	<b>83</b>

## **LIST OF TABLES**

<b>Table 1: Summary of DMA 601, 605, 607 &amp; 608 of Contract No. ICB 2.7 Components</b> .....	<b>5</b>
<b>Table 2: Road Classification in Dhaka</b> .....	<b>11</b>
<b>Table 3: Description of Each DMA under Package No. ICB 02.7</b> .....	<b>14</b>
<b>Table 4: Environment-Related Design Features of the Package</b> .....	<b>15</b>
<b>Table 5: Public Consultations Conducted in DMA 601</b> .....	<b>26</b>
<b>Table 6: GRC of DMA 601</b> .....	<b>29</b>
<b>Table 7: Institutional Roles and Responsibilities for Safeguards Implementation</b> .....	<b>32</b>
<b>Table 8: Capacity Building and Training Program</b> .....	<b>34</b>
<b>Table 9: Environmental Mitigation Measures Action Plan</b> .....	<b>36</b>
<b>Table 10: Indicative Cost for EMP Implementation</b> .....	<b>59</b>

## EXECUTIVE SUMMARY

1. **Background.** The ongoing Dhaka Water Supply Sector Development Project (DWSSDP) covers approximately 80% of the area and 70% of the population of Dhaka City and is jointly financed by Asian Development Bank (ADB) and the Government of Bangladesh. The aim of the Project is to improve the water supply network of Dhaka City by dividing the network into approximately 100 District Metering Areas (DMAs); rehabilitation or replacement, of water lines between 75 and 450 mm diameter; and replacement of approximately 175,000 connections serving more than 8 million people. The project for package no. ICB 2.7 is prepared as part of a new project titled - Dhaka Environmentally Sustainable Water Supply Project (DESWSP) - but implemented similarly as contracts under DWSSDP.

1. **Program description.** The project is expected to contribute to sustained economic growth and public health improvement, in urban water supply sector, particularly in Dhaka Metropolitan Area, through the improvement of living standard in the basic human needs by improving the water supply. The supply of clean water will impact on reduction in child mortality and improvement of general health, conversion to economic activity by saving time to fetch and to store water, and conservation of precious natural resources the surface and ground water.

2. **Implementation arrangements.** Dhaka Water Supply and Sewerage Authority is both the Executing Agency (EA) and the Implementing Agency (IA). A Project management unit (PMU) has been established. The PMU will be assisted by a Design and Management Consultants in (i) distribution system and quality improvement; (ii) capacity building and institutional strengthening; and (iii) project management and implementation support.

3. **Project investments.** This IEE was prepared during outline design for rehabilitation of distribution networks in 16 district metering areas (DMAs) as covered by Package No. ICB 2.7 and now it has been updated based on approved Environmental Management Plan (EMP) for 4 DMAs are DMA 601, 605, 607 & 608. Among these four DMAs, civil works of DMA 601 under this package has begun implementation on 4<sup>th</sup> September 2016. Under the contract of Package No. ICB 2.7, the following works are planned: (i) survey and documentation including detailed design, specifications, preparation of quality assurance and design report, and design control services of 16 DMAs (DMA 601 to 616); (ii) supply, laying and commissioning of distribution, transmission, and reticulation pipes in the 16 DMAs; (iii) rehabilitation of service connections; and (iv) rehabilitation of tubewells. Package No. ICB 2.7 is expected to have the following benefits: (i) rehabilitation of distribution network which will result in substantial reduction in water losses in the project area; and (ii) proper accounting for use of water and system losses by installation of metered connections. For efficient and effective execution, the package is being implemented through a design-built contract, i.e. the civil works contractors also prepare the detailed designs.

4. **Legal framework.** The legal framework and principles adopted for addressing environmental issues in the proposed project have been guided by the existing legislation and policies of the Government of Bangladesh and ADB.

5. ADB requires the consideration of environmental issues in all aspects of its operations, and the requirements for environmental assessment are described in ADB's Safeguard Policy Statement (SPS), 2009. According to the SPS, environmental assessment is required for all projects under a program loan modality. This IEE report was prepared to meet the following objectives: to (i) assess the project's likely positive and negative direct and indirect impacts to

physical, biological, socioeconomic, and physical cultural resources in the project's area of influence; (ii) identify mitigation measures and any residual negative impacts that cannot be mitigated; (iii) describe the process undertaken during project design to engage stakeholders, and the planned information disclosure measures and the process for carrying out consultation with affected people and facilitating their participation during project implementation; (iv) describe the project's grievance redressal mechanism for resolving complaints about environmental performance; (v) present the set of mitigation measures to be undertaken to avoid, reduce, mitigate, or compensate for adverse environmental impacts; (vi) describe the monitoring measures and reporting procedures to ensure early detection of conditions that necessitate particular mitigation measures; and (vii) identify who is responsible for carrying out the mitigation and monitoring measures.

6. **Environmental management plan.** The project site is located in the built-up area of Dhaka City and is not within or adjacent to environmentally sensitive areas such as protected areas, wetlands, buffer zones of protected area, and special areas for protecting biodiversity.

7. Planning principles and design considerations were reviewed and incorporated into the site planning process whenever possible; thus, environmental impacts due to the project design or location are not significant. However, the social impacts (access disruptions) due to construction activities are not avoidable, as residential and commercial establishments exist along the project corridor. Resettlement Plan (RP) of DMA 601 has been developed and RP for DMA 607 & 608 are being developed in accordance with ADB SPS, 2009 and Bangladeshi laws and regulations.

8. An environmental management plan (EMP) was developed during project preparation and the EMP has now been updated based on detailed design of DMA 601, 605, 607 & 608 to provide specific actions deemed necessary to assist in mitigating the environmental impacts, guide the environmentally-sound execution of the proposed project, and ensure efficient lines of communication between the implementing agency, project management unit, consultants, and contractors. The EMP also provides a proactive, feasible, and practical working tool to enable the measurement and monitoring performance on-site.

9. **Public consultation.** The public participation process included (i) identifying interested and affected parties (stakeholders); (ii) informing and providing the stakeholders with sufficient background and technical information regarding the proposed development; (iii) creating opportunities and mechanisms whereby they can participate and raise their viewpoints (issues, comments, and concerns) with regard to the proposed development; (iv) giving the stakeholders feedback on process findings and recommendations; and (v) ensuring compliance to process requirements with regards to the environmental and related legislation. The IEE includes the activities undertaken during detailed design stage to engage the stakeholders, and planned information disclosure measures and processes for carrying out consultation with affected people and facilitating their participation during implementation stage.

10. **Grievance redressal mechanism.** The program's grievance redressal mechanism provides the citizens with a platform for redressal of their grievances and describes the informal and formal channels, time frame, and mechanisms for resolving complaints about environmental performance.

11. **Categorization.** As per ADB SPS 2009 the project is classified as environmental category B and does not require further environmental impact assessment. As per Bangladeshi

laws, the proposed project requires a Location Clearance Certificate and an Environmental Clearance Certificate (ECC) from the Department of Environment (DoE).



## I. INTRODUCTION

### A. Purpose of the Report

12. The ongoing Dhaka Water Supply Sector Development Project (DWSSDP) covers approximately 80% of the area and 70% of the population of Dhaka City and is jointly financed by Asian Development Bank (ADB) and the Government of Bangladesh. The aim of the Project is to improve the water supply network of Dhaka City by dividing the network into approximately 100 District Metering Areas (DMAs);<sup>1</sup> rehabilitation or replacement, of water lines between 75 and 450 mm diameter; construction / rehabilitation of 39 overhead reservoirs; and replacement of approximately 175,000 connections serving more than 8 million people.

13. The project will contribute to sustained economic growth and public health improvement, in urban water supply sector, particularly in Dhaka Metropolitan Area, through the improvement of living standard in the basic human needs by improving the water supply. The supply of clean water will impact on reduction in child mortality and improvement of general health, conversion to economic activity by saving time to fetch and to store water, and conservation of precious natural resources the surface and ground water.

14. DWASA will be both the Executing Agency (EA) and the Implementing Agency (IA). The project will implement network rehabilitation in Zones 2 and 6 covering 31 hydraulic areas (DMAs). The project is divided into five contracts (packages) and the implementation of each package will approximately take about 30 to 36 months, with for Package No. ICB 2.7 about 30 months.

15. DWSSDP has been classified by ADB as environmental assessment category B (some negative impacts but less significant than category A). The IEE was prepared similarly as to previous IEEs under DWSSDP. The environmental impacts of the investments under Package No. ICB 2.7 were identified and assessed as part of the planning and design process, and actions will be taken to reduce those impacts to acceptable levels; this report has been reviewed again and updated during the detailed design stage. An environmental assessment using ADB's Rapid Environmental Assessment (REA) Checklist for Water Supply (Appendix 1) was conducted, and results of the assessment show that the project is unlikely to cause significant adverse impacts. Thus, this IEE was prepared in accordance with ADB SPS's requirements for environment category B projects.

16. The activities under the Package No. ICB 2.7 includes i) survey and documentation including detailed design, specifications, preparation of quality assurance and design report, and design control services (ii) supply, laying and commissioning of distribution, transmission, and reticulation pipes; (iii) rehabilitation of service connections; and (iv) rehabilitation of production tubewells (PTWs) headworks. The proposed project is expected to have the following benefits: (i) rehabilitation of distribution network which will result in substantial reduction in water losses in the project area; and (ii) proper accounting for use of water and system losses by installation of metered connections.

---

<sup>1</sup>A DMA is defined as a geographical area served by water distribution network which can be isolated hydraulically from neighboring areas.

## II. POLICY, LEGAL, AND ADMINISTRATIVE FRAMEWORK

### A. ADB Policy

17. ADB requires the consideration of environmental issues in all aspects of ADB's operations, and the requirements for environmental assessment are described in ADB SPS, 2009. This states that ADB requires environmental assessment of all project loans, program loans, sector loans, sector development program loans, loans involving financial intermediaries, and private sector loans.

18. **Screening and categorization.** The nature of the environmental assessment required for a project depends on the significance of its environmental impacts, which are related to the type and location of the project; the sensitivity, scale, nature, and magnitude of its potential impacts; and the availability of cost-effective mitigation measures. Projects are screened for their expected environmental impacts, and are assigned to one of the following four categories:

- (i) **Category A.** Projects could have significant adverse environmental impacts. An EIA is required to address significant impacts.
- (ii) **Category B.** Projects could have some adverse environmental impacts, but of lesser degree or significance than those in category A. An IEE is required to determine whether significant environmental impacts warranting an EIA are likely. If an EIA is not needed, the IEE is regarded as the final environmental assessment report.
- (iii) **Category C.** Projects are unlikely to have adverse environmental impacts. No EIA or IEE is required, although environmental implications are reviewed.
- (iv) **Category FI.** Projects involve a credit line through a financial intermediary or an equity investment in a financial intermediary. The financial intermediary must apply an environmental management system, unless all projects will result in insignificant impacts.

19. **Environmental management plan.** An EMP, which addresses the potential impacts and risks identified by the environmental assessment, shall be prepared. The level of detail and complexity of the EMP and the priority of the identified measures and actions will be commensurate with the project's impact and risks.

20. **Public disclosure.** ADB will post the following safeguard documents on its website so affected people, other stakeholders, and the general public can provide meaningful inputs into the project design and implementation:

- (i) For environmental category A projects, draft EIA report at least 120 days before Board consideration;
- (ii) Final or updated EIA and/or IEE upon receipt; and
- (iii) Environmental monitoring reports submitted by the Project Management Unit (PMU) during project implementation upon receipt.

21. This project, as explained above has been classified by ADB as Category B, because it is not expected to have major negative environmental impacts. Under ADB procedures such projects require an IEE to identify and mitigate the impacts, and to determine whether further study or a more detailed EIA may be required.

## **B. National Laws**

22. The implementation of the projects will be governed by Government of Bangladesh environmental acts, rules, regulations, and standards. These regulations impose restrictions on the activities to minimize/mitigate likely impacts on the environment. It is the responsibility of DWASA to ensure projects are consistent with the legal framework, whether national, state, or municipal/local. Compliance is required in all stages of the project, including design, construction, and operation and maintenance.

23. The main provisions for environmental protection and pollution control in Bangladesh are contained in the Environmental Conservation Rules (ECR) 1997. This legislation also provides the principal mechanism for assessing and mitigating the environmental impacts of projects, both existing and proposed. Projects are classified as green, orange, or red depending on their location and environmental impacts, and Schedule 1 of the law indicates that “water, power and gas distribution line laying/relaying/extension” are considered as red category activities.

24. Rule 7 states that the proponent of such projects must obtain a Location Clearance Certificate and an Environmental Clearance Certificate (ECC) from the DoE. For proposed Red Category projects this requires submission to the relevant DoE Divisional Officer of the following:

- (i) Completed application for ECC, and the appropriate fee, shown in Schedule 13 of the Rules;
- (ii) Report on the feasibility of the project;
- (iii) Report on the IEE for the project, terms of reference (TOR) for an EIA of the project, and its process flow diagram; or an EIA prepared from a previously approved TOR, layout plan, process flow diagram, and design and time schedule;
- (iv) No objection certificate from the local authority;
- (v) Emergency plan relating adverse environmental impact and plan for mitigation of the effect of pollution; and
- (vi) Outline of the relocation and rehabilitation plan (where applicable).

25. Discussions with DoE in August 2006 suggested that the IEE, Resettlement Framework and other study reports prepared during DWSSDP preparation in 2006 should fulfill a substantial proportion of the national EIA requirements. Upon submission of the necessary documents including draft IEE for ICB 02.7, Environmental Clearance Certificate is obtained and is available at Project Management Unit (PMU) office.

## **III. DESCRIPTION OF THE PROJECT**

### **A. Existing Condition and Need for the Project**

26. At present DWASA provides around 2.0 million cubic meters of water per day to the population of Dhaka. Approximately 85% of this water comes from over 600 deep tube wells (production tube wells) spread throughout the city area. The aggregate transmission and distribution network length is around 3,000 km with over 250,000 service connections. The project is needed because DWASA presently provides an inadequate water supply service to the residents of Dhaka, which has insufficient pressure, suffers significant losses, is rapidly depleting the groundwater resource, and delivers insufficient cost recovery to the government.

The project will address all of these issues by refurbishing the existing network to repair leaks, increase capacity and pressure, remove illegal connections, and provide a new system of metering to streamline leak detection and aid cost recovery.

27. The 16 DMAs is characterized by high population density, narrow roads, and high traffic congestion at most times of the day. The water supply situation is characterized by the high number of deep tube wells, inadequately sized, leaking and low quality pipes, low workmanship, low operating pressures, inaccurate and inadequate data about location of pipes and service connections, and inaccurate and inadequate data about location of other utility lines.

28. The network in the 16 DMAs is currently supplied by limited surface water and ground water from tubewells across the city. There is no clear distinction between transmission mains and distribution mains which mean laterals and reticulation are often connected to large diameter pipes resulting in loss of pressure and increased leakage. The pipes are mainly buried towards the centre of roads and streets, with larger diameter pipes (>150 mm) generally located in main roads and smaller pipes in minor roads. The pipes are built from a range of asbestos cement (AC), ductile iron (DI), steel (MS) and polyvinyl chloride (PVC) pipe. The majority of newer pipe is PVC.

## **B. Proposed Components**

29. Package No. ICB 2.7 includes (i) rehabilitation and extension of 376-km (as per outline design) distribution network in 16 DMAs (DMA 601 to 616); (ii) replacement of all fitting of all production tube wells;<sup>2</sup> (iii) service connections including installations of meter chamber, domestic meters and floating valve; and (iv) installations of valves, bulk meters and loggers, etc. For efficient and effective execution the package will be implemented through a design-built contract, i.e. the civil works contractors will also prepare the detail designs. The package is being implemented in groups containing 3 -4 DMAs in each group. Appendix 7 shows an implementation plan of package ICB 02.7 where DMA 601, 605, 607 & 608 are considered as 3<sup>rd</sup> Group. The main activities (the works) of the contract is expected, as a minimum, to comprise the following steps:

- (i) Survey;<sup>3</sup>
- (ii) Resettlement plan implementation;<sup>4</sup>
- (iii) Design comprising of (a) detailed survey of area (location of water pipes, service connections, valves, tube wells, bulk meters, and other utility lines); (b) detailed network modelling of areas and updating of basic model (outline design) with additional information obtained from survey; and (c) submission of detailed design package of area including design drawings (1:2000) and expected work methodologies for each DMA;

---

<sup>2</sup> The Contractor will be responsible to replace all fittings from existing tube well head to the delivery main, e.g. 200/250 mm diameter pipe, non-return valve, pressure meter, flow meter, gate valve, washout pipe with valve, air release valve, bends, flange adapter, support, among others as indicated in the detailed design and drawings for production tube wells.

<sup>3</sup> To establish (i) location of existing water and other utility infrastructure; (ii) location of service connections; and (iii) location of existing valves, meters, and production tube wells

<sup>4</sup> The Contractor will be responsible in implementing the Resettlement Plan (RP) prepared by DWASA and/or resettlement NGO. No civil works will be allowed to begin until all compensation to affected persons is paid.

- (iv) Pipe works comprising of (a) disconnection of cross connections between DMAs; (b) installation of bulk meters and valves at all needed cross connections between DMAs; (c) repair/rehabilitation or replacement of 305.296 km existing pipes according to outline design;<sup>5</sup> (d) extension of network to areas not adequately served (70.988 km);<sup>6</sup> and (e) pressure testing of each section of repaired/rehabilitated/replaced or new laid pipe.
- (v) Service connections<sup>7</sup> comprising of (a) installing a meter chamber for each existing connection; (b) connecting the meter chamber with the water pipes, using new materials; (c) installing water meter in meter chamber; (d) pressure testing of each service connection; and (e) installing float valves at the first reservoir of the household.
- (vi) Other works such as (a) repair of roads according to given requirements wherever needed; (b) repair of other utility lines in case they are damaged during the work; and (c) provision of alternative sources of water for people while being disconnected from water supply system during the implementation.

30. Due to the significant pressure on the transport network in Dhaka, it is foreseen that any open trenching in or near roads, particularly in the larger roads, will only be permitted during the night. For this reason and to minimize public disturbance, it is expected that trenchless techniques<sup>8</sup> will be used for replacement and rehabilitation as well as network extension and service connections. In situations where the contractors prefer the traditional trenching technology,<sup>9</sup> the case must be justified and approved by the Project Manager.

31. Table 1 summarizes the components of DMA 601, 605, 607 & 608 of Package No. ICB 02.7.

**Table 1: Summary of DMA 601, 605, 607 & 608 of Contract No. ICB 2.7 Components**

Item	Description	Remark	Unit	Quantity
1.	Installation of distribution pipes through open trench, pipe bursting, and horizontal directional drilling (HDD) method including installation of	- Diameter of pipes between 110 and 560 mm. - Designed to distribute water within a DMA.	m	101660.9

<sup>5</sup> The term "pipe replacement" means that the existing pipe will be replaced, either by the traditional open trench method, where the existing pipe will be abandoned and a new pipe will be installed or by pipe bursting, where the existing pipe will be used as a host pipe which will be cut open, expanded and a new pipe will be installed inside the old pipe.

<sup>6</sup> The term "pipe extension" means the laying of a new pipe where no distribution pipes previously existed. Laying pipes in un-served and underserved area and replacing spaghetti lines (bunch of small diameter coil pipes) with new reticulation pipe lines will be considered as extension work. Areas which have recently been developed on an ad-hoc basis are considered partly served, as the secondary or tertiary water lines do not reach all houses. In these areas water supply is often supplied through long coil pipes laid by the owner of the house on the side of the road.

<sup>7</sup> The term "service connection" means the pipe between the water distribution network, the distribution or reticulation pipe, and the water meter installed in the meter chamber inside the boundary of the consumer/customer. It is assumed that all existing service connections need to be replaced. This is due to the long tradition of the use of substandard quality materials and low quality workmanship when connecting customers to the water network.

<sup>8</sup> This involves the use of horizontal direction drilling (HDD) which involves a hydraulic machinery to drill a horizontal tunnel for a new pipe or to insert a flexible plastic lining inside an existing pipe, so no trenches are dug, and excavation is limited to the entry and exit points.

<sup>9</sup> The size of trenches will depend on the diameter of the pipe, but most will be 0.3 to 0.7 m in width and 1.4 to 1.8 m deep.

Item	Description	Remark	Unit	Quantity
	burried gate valves and wash out upto 200 mm dia, data loggers (dls), non return valves as required and approved, but excluding valves and dls for production tube wells (PTWs) & interconnection chambers for isolation of DMAs	<ul style="list-style-type: none"> <li>- Number of service connections shall be a maximum 80 to 100 per km for pipes of 200 mm diameter or less. In general, connections to pipes above 200mm diameter shall not be made.</li> <li>- Pipe diameter of 315 mm or more to be designed to transfer water from one area to another, one DMA to another, or between major facilities of a water supply system such as from a PTW or WTP to storage tank or distribution area.</li> <li>- No service connections allowed directly from 315 mm or above dia pipes.</li> </ul>		
2.	Installation of reticulation pipes through open trench and HDD method including installation of burried Gate Valves, Wash Out	<ul style="list-style-type: none"> <li>- Pipe diameter: 75 mm</li> <li>- Reticulation lines may be installed parallel to distribution mains or in tertiary roads to provide service connections.</li> <li>- Reticulation pipelines are laid to minimize road crossing of the service connections; reduce the length of the service connection lines and to reduce the number of connections at a single point on the main pipe line.</li> </ul>	m	27300.5
3.	Rehabilitation of service connections of length as required including supply of saddles, Ferrule, transition coupler, gate valves, float valves, meter chamber incl. required fittings for the meter to be placed within 0.6 meter from ground level all complete (water meters are of Employer's Supply)	<ul style="list-style-type: none"> <li>- Pipe diameter: 20 to 50 mm.</li> <li>- A service connection is identified as the connection from the distribution pipes or reticulation pipeline to a customer's water meter. The distribution network (including tertiary pipes) shall be designed in a manner where the length of the service connections will be about ±15meter.</li> <li>- There will be service connections for domestic, commercial, industrial, institutional, public standpipes and yard or community connection for community/slum dwellers.</li> </ul>	nos.	10,230
4.	Upgrading of Tube Wells delivery pipes including replacement of Gate Valves, Non Return Valve, Air Release Valve, Bulk Water Meter, supply and fabrication of MS Pipe, Wash Out arrangement with valve, Tee, Bend, standard fire hydrant outlet, flange etc, supports, fittings and accessories (where necessary) all complete as per drawing (valves and meters are of Employer's supply)	<ul style="list-style-type: none"> <li>- Upgrade of pump facilities of the existing production tube well is beyond the scope of this contract. The contractor shall however be responsible to replace all fittings from the existing tube well head to the delivery main, e.g. 200 / 250 mm dia. pipe, etc.</li> </ul>	nos.	24
5.	Construction of Gate Valve Chamber, Interconnection Chamber and Interconnection with transmission main of approved design including necessary fittings and fixtures, excavation and back filling all complete (valves, meters and data loggers are of Employer's Supply)	<ul style="list-style-type: none"> <li>- Each interconnection point will be controlled by a bulk meter (monitored by a flow logger) and a valve which may, in the future, be controlled and operated by a SCADA system.</li> </ul>		
5a.	Construction of RCC Gate Valve Chamber for pipeline of 315 mm dia and above.		nos.	46

Item	Description	Remark	Unit	Quantity
5b.	Construction of RCC Interconnection chamber for isolation of DMA where required including installation of Pressure Sustaining Valves, Pressure Reducing Valves, Air Release Valves, Non Return Valves, Bulk Water Meters and Data Loggers with all fittings, fixtures all complete as per approved design, drawing and direction of project manager		nos.	26
5c.	Interconnection with the existing water transmission main from 300 mm to 600 mm diameter where required including supply of Tee, Reducer with fittings, fixtures all complete as per approved design, drawing and direction of project manager.		nos.	2
5d.	Construction of RCC Air Release Valve Chamber for pipeline including installation of data loggers with necessary fittings, fixtures all complete as per approved design, drawing and direction of project manager.		nos.	18
6.	Testing, repair, replacement, cleaning and disinfection of Existing Pipelines all complete	The completion of rehabilitation/replacement or extension of the pipe laying works in a section will be followed by pressure testing. The leakage tests shall be conducted at the same time as the pressure test. After pressure testing, the pipeline shall be washed out and disinfected.	m	0

### C. Implementation Schedule

32. The project ICB 02.7 is to be implemented over a period of 2.5 years. The detailed design stage has to be completed in 17 months, and the construction period will cover 28.5 months.

## IV. DESCRIPTION OF THE ENVIRONMENT

### A. Methodology Used for the Baseline Study

33. **Data collection and stakeholder consultations.** Data for this study has been collected through detailed survey, discussion with stakeholder agencies, and field visits to the proposed subproject sites.

34. **Data analysis and interpretation.** The data collected has been analyzed and interpretations made to assess the physical, biological, and socioeconomic features of the project area. The relevant information is presented in the succeeding paragraphs.

### B. Physical Characteristics

35. **Location.** The service areas of DMA 601, 605, 607 & 608 of Package no. ICB 2.7 is under the jurisdiction of Dhaka North City Corporation and Dhaka South City Corporation lying in DWASA operation Zone 6.

#### **DMA 601**

DMA 601 is known as Banasree Residential Area within Rampura of Dhaka City. The project area is bounded by DMA 602 & 607 at the East, DMA 603, 607,609,617 at the south, DMA 610 at the west and Begunbari khal at north, covering a total area of about 0.793 km<sup>2</sup>.

#### **DMA 605**

The locaton of this DMA is confined within area locally known as Nandipara under Sobujbag and Rampura Thana in Dhaka City. The DMA is bounded by DMA 602 at the North, DMA 604 at the West and DMA 606 at the South-west, covers a total area 4.5036 km<sup>2</sup>.

**DMA 607**

The location of the working area is confined within DMA 607 locally known as Meradia area under Rampura Thana in Dhaka city. This working area is bounded by DMA 603 at the East, DMA 602 & 604 at the west and DMA 601 at north, DMA 606 at South, covers a total area 0.596 km<sup>2</sup>.

**DMA 608**

This is planned but very densely developed area with 4 DTWs. There are small slum areas to the north and east. The location of the working area is locally known as Khilgaon A-Block area under Khilgaon Thana in Dhaka city. This DMA area is bounded by DMA 606 at the east, DMA 603 & DMA 617 at the North, DMA 612 & DMA 613 at the west, and it covers a total area of 0.83 km<sup>2</sup>.

36. **Topography and Soil.** The project area is at the northern edge of the delta in the centre of the country, between the confluences of the rivers. and the project area is flat and low lying particularly around the delta, which floods extensively in the rainy season. The influence of the rivers is evident in the soils, which are almost entirely alluvial, and generally fertile, with a predominantly loam and silt consistency.

37. **Climate.** The climate is sub-tropical, with a typical three season pattern. Rainfall is <30 mm per month and average temperatures around 20°C. Temperatures start to rise in March and reach the annual maximum of around 29°C in April-May, when daytime temperatures can exceed 40°C. The monsoon begins in May-June as hot air rises over the Indian subcontinent, creating low pressure areas into which rush the cooler moisture-laden winds from the Indian Ocean and the Bay of Bengal. Around 70-80 % of the annual rain falls during this time. The rain is often accompanied by strong winds, sometimes exceeding 100 kilometers per hour. Temperature and rainfall both decline post-monsoon, returning rapidly to the winter lows.

38. **Air Quality.** The main causes of the poor air quality in the project area are: (i) poor roads and traffic management leading to severe traffic congestion; (ii) use of high sulphur diesel by buses and trucks, and inadequate control of emissions; (iii) heavy industrialization, and use of cheaper high-sulphur fuels (coal, wood, and tires) by smaller industries like brick kilns; and (iv) poor solid waste management, so burning is the common method of treating garbage.

39. **Geology and Seismology.** According to the National Seismic Zoning Map produced by the Geological Survey of Bangladesh (GSB), Dhaka lies at the end of the Dauki fault in an area of medium seismic risk. This means that shocks of moderate intensity are possible, with a probable maximum magnitude of 6.5-7 on the Richter scale. Seismic events in Bangladesh are relatively infrequent but historically have been severe, such as the earthquakes of 1930 and 1950 that caused widespread damage throughout the country, and the earthquake in 2004 that damaged large parts of Dhaka City.

**C. Ecological Resources**

40. **Rivers.** Dhaka City, where the 16 DMAs are located, is enclosed between the Turag-Buriganga River in the west and the Balu-Sitalakhya River in the east, both of which drain into the Meghna in the south, along with the Dhaleswari, old Brahmaputra and other rivers outside the city limits. The Ministry of Environment and Forests estimates that 80% of the sewage produced by the 15 million people in Dhaka and surrounding areas enters the rivers untreated,

and most of the 7,000 industries dispose of their waste to drainage ditches and rivers without treatment (Dhaka Environment Programme, 2005). It is not surprising that the ecology of the rivers has deteriorated under such pressure, and declining fish catches (26,476 tons in 1983 to 84 to 6,095 tons in 1996 to 97 in North Central Region) are just one indicator of the malaise.

41. **Other Aquatic Habitats.** There are a variety of other aquatic habitats in the city, including man-made lakes in residential areas (e.g. Gulshan), permanent and ephemeral pools in natural lowlands (known as bheels), and flooded borrow pits excavated for building material. These are of little ecological value as the water is frequently polluted, and these areas are often characterized by dense growths of the water hyacinth *Echicornica crassipes*, which out-competes other plants through its rapid growth, although species such as water chestnut and lotus can be seen in places.

42. **Terrestrial Ecology.** There are few natural terrestrial habitats in the subproject areas as in other parts of Dhaka city, because of the seasonal flooding and the urbanization of the city, and agricultural development in the outlying areas, which destroyed the natural habitats many years ago. Terrestrial plants are now mainly limited to trees, shrubs and flowers grown alongside roads and in parks and gardens in the city, and the crops and fruit trees planted in agricultural areas. The terrestrial fauna is very limited as a result, and mainly consists of animals able to live close to man, such as lizards and geckoes, scavenging birds like house sparrows and crows, and mice, rats and other rodents. There are more animals in the farming areas, but even these are species commonly found close to man, such as cattle egrets.

43. **Protected Areas and Endangered Species.** There are no areas in or around the DMAs 601, 605, 607 & 608 that are designated and protected for nature conservation, and no rare or endangered species. This is because as explained above terrestrial habitats have been destroyed to provide land for urbanization, and aquatic habitats are damaged and degraded by water pollution, infilling, and other anthropogenic activities.

#### **D. Economic Development**

44. **Industry.** Manufacturing is the most important activity, and because of the low cost of labor, many factories have links with major companies in Europe, to which they supply low cost garments and other products. The main industries are leather tanneries, and textile production; but there are factories manufacturing a wide range of other products including fertilizers, pesticides, chemicals, pharmaceuticals, rubber, plastics, cement, and foodstuffs including salt, sugar, and rice. There are also heavier industries including iron and steel mills, ship repair yards, power plants, oil refineries, and pulp and paper mills.

45. **Water supply.** The main features of the existing water supply system are as follows:

- (i) 100% of the supply is from groundwater via 23 production tube wells in DMA 601, 605, 607 & 608;
- (ii) This water is treated by injection of liquid chlorine, but not at all production tube wells;
- (iii) Around 18% water is supplied from surface water in Dhaka city, extracted from Buriganga and Sitalakhya Rivers;
- (iv) This is treated at the Chatnighat (39 MLD) and Saidabad (450 MLD) Surface Water Treatment Plants (SWTP) by sedimentation, filtration, and chlorination;
- (v) Water from all sources is distributed via a 2,400 km network of underground pipes in the city (100-450 mm in diameter), mainly buried in roads;

- (vi) Water pressure in the area supplied by Saidabad SWTP (Zones 1, 2, 3, and 6) is good near the ring main but poor near the extremities;
- (vii) Water is treated to Bangladesh drinking water standards, but leaking pipes, low pressure and inadequate treatment/disposal of wastewater often cause contamination; and
- (viii) As indicated above, other problems are loss of water through leaks and illegal house connections, a rapidly reducing groundwater table, and inadequate cost recovery.

46. **Sanitation.** Most of the city is not connected to a mains sewer, and most people use water-operated toilets with septic tanks. These do not operate as soak ways because of the high water table, and the contents discharge into natural drains and low ground, causing unsightly areas, health risks, and water pollution; People living in the slums and other poor areas, use pit latrines, open latrines or other unsanitary methods.

47. **Drainage.** The city drainage system consists of surface and underground elements, maintained by Dhaka City Corporation (DCC) and DWASA respectively. Surface drains are mainly brick and concrete channels (covered and uncovered), built by the Roads and Highways Department alongside roads, and the Rajuk Planning Authority in residential areas. Underground drains are brick-sided tunnels or AC pipes, built by DWASA. The system covers most of the city but does not function properly because drains are blocked with refuse and building rubble and the design is inadequate to cope with the volume of wet season flows.

48. **Solid waste.** Solid waste is the responsibility of DCC, who provide a system through which vans operated by a nongovernment organization (NGO) collect refuse from houses and businesses each day, and deposit it at collection points throughout the City. These are emptied daily by DCC, who take the refuse to dumpsites. However, the sites are not engineered or selected carefully, and are often simply areas of open ground in and around the City, where the refuse creates an unsightly appearance and a health hazard. Dumping areas may be covered with sand and soil when full, but this creates a further hazard as these areas may then be built upon and there is a risk of subsidence as the refuse decomposes, and liberated gases can explode if ignited.

49. **Transportation.** The project area heavily congested throughout much of the day, because roads are insufficient for the volume of traffic, and problems are exacerbated by driver indiscipline and ineffective policing of traffic laws. There are a multitude of smaller cross-linking roads, many of which are narrow and suitable for only one or two vehicle widths, which also become congested as drivers seek alternative routes. The problem is compounded by the very large population of Dhaka, which creates a large volume of pedestrian traffic, and the vast array of public and private transport vehicles seeking customers. These include large numbers of buses, taxis, auto rickshaws, private cars, and bicycle rickshaws. These operate throughout the city at both regulated and unregulated stops, and the buses and taxis provide links to surrounding districts.

#### **DMA 601**

Total road length in this DMA was measured 18.62 km during survey. Most of the roads in DMA 606 are Cement Concrete (CC) and some are Katcha, Brick Carpeting and Herring Bone Bond (HBB) types. The DMA is consisted of three types of roads (secondary, tertiary and main) with varying widths ranging from 2.0m -15.5m.

**DMA 605**

The DAM has different types of roads. Majority of the roads are Katcha type. There are roads of Bituminous Carpeting (BC), Cement Concrete (CC) and Brick Carpeting with varying widths from 0.6m-11.00m.. Most of the roads are poorly maintained. Medium level traffic congestion is seen during the rush hours. There are some underground sewerage networks and storm/surface drainage networks in this area. The survey report also tells that the existing water supply system of this DMA is consisted of pipe with dia of 100, 150, 200 & 300mm made of UPVC and Ductile Iron (DI). Total length of existing pipe network is 32.019 km.

**DMA 607**

Total length of roads in this DMA was measured 16.016 km during survey. Most of the roads are Cement Concrete (CC), some are Katcha (earthen), Brick Carpeting (BC) and Herring Bone Bond (HBB) types. The road widths are varied and they range from 0.9m-5.8m.

**DMA 608**

Most of the roads in this DMA are Cement Concrete (CC) and some are Katcha and Brick Carpeting (BC) types which are ill maintained. The DMA 608 is consisted of three types of roads (secondary, tertiary and main) with varying widths ranging from 1.8m -25.1m.

50. **Classification of roads by size and by surface type.**<sup>10</sup> There is no standard classification of roads based on traffic volume, tonnage, location and function they have to perform. However, depending on use the roads are classified as VIP roads, main roads and other roads. For road restoration purposes the roads are also classified as asphalt road, bituminous road, reinforced concrete cement (RCC)/concrete cement (CC) road, brick pavement, macadam and earthen road depending on construction and surface type.

51. As there is no control on movement of heavy traffic, DWASA considers all types of roads as heavy duty road for design purpose. Dhaka city roads are with foot paths, underground/surface drainage, sewer line, gas, electricity, telephone and other utility services. In order to be systematic and for convenience of work the roads are classified based on width and are defined as Table 2 below.

**Table 2: Road Classification in Dhaka**

	<b>Road Classification</b>	<b>Description</b>
A.	By Width	
1.	< 2 metre width	The tertiary roads in unplanned areas are usually narrow and mostly less than 2 metres where no vehicles or only one car can pass at a time. These categories of roads will be treated as tertiary roads / lane / access road. The tertiary roads may be of earth, brick pavement, macadam or RCC / CC type. These types of roads have no footpath, have no proper drains and normally a limited number of other utility services beneath.
2.	4 metre width	The internal roads of a planned area and the branch of main roads are within 2-4 m width and are classified as secondary roads. The secondary roads are usually of bituminous surfacing, although RCC / CC and brick pavement and macadam type may constitute a secondary road. These roads may be with or

<sup>10</sup> Categories of roads as per surface types are important for road restoration purposes. The pavement restoration, where required, will be carried out by Dhaka City Cooperation (DCC) when all backfill has been settled for 6 weeks. For this purpose DCC will have to be paid as per surface types of the roads. DWASA will apply for the road cutting permission and the contractor must pay therefore. The road cutting plans necessary for the application must be prepared by the contractor.

	Road Classification	Description
		without foot path and in most have all types of utility services beneath.
3.	> 4 metre width	The main roads and VIP roads of Dhaka city are larger than 4 m and are of asphalt / bituminous surfacing. These are heavy tonnage roads, traffic volume is large and traffic congestion is a common feature with these categories of roads. These roads are always with foot path and all other utility services beneath.
4.	Major roads	Main roads are the major roads of Dhaka city allowing all types of traffic including three wheeler rickshaws and heavy truck/lorries.
5.	VIP roads	These are also the main roads of Dhaka city allowing all types of traffic including heavy truck/lorries except the three wheeler rickshaws and pushcart.
B.	By Surface Type	
1.	Asphalt and Bituminous Road	Major roads of Dhaka city are of asphalt/bituminous flexible pavement consisting of wearing course, base course, sub-base and sub-grade. The pavement structure of roads >4 m (main and VIP) have all these elements, however, narrower roads depending on site and traffic conditions may not have the same design.
2.	RCC / CC	Special and access roads are of rigid pavement type and are made of RCC / CC. Usually a rich mixture of cement, sand and coarse aggregate is laid in a single layer for this type of roads.
3.	Macadam / Brick Pavement	Areas less important and under developed have macadam and brick pavement (200 mm) without base and sub-base course and usually designed for light traffic.
4.	Earth / Kutchra Road	There are also earth / kutchra roads in areas newly developed and sometimes concrete rubbish is used for surfacing.

## 52. Land Use.

53. Present land use is mainly urban in the centre however other land uses as well, including residential units between and above shops in the increasing numbers of high-rise buildings, and some industry. .

54. **Power Sources and Transmission.** Power in the subproject areas is provided by Dhaka Electric Supply Authority (DESA) through a network of electricity pylons and poles, mainly located beside roadways. This provides connections to individual houses, and revenue collection is by individual household meters. The supply is erratic and power cuts are frequent, generally lasting 1-2 hours each day. Hotels, businesses and the more wealthy residents increasingly use their own generators to augment the DESA supply.

## 55. Other Economic Development.

There are few other economic activities in the city, other than those already described. There are no exploitable mineral resources, although mining of sand from river beds to raise the level of land for building is a major activity in floodplain areas. There is also little tourism, because the poor infrastructure and widespread flooding in the months of the northern summer discourage visitors from Europe and elsewhere. As a result, tourism is mainly limited to domestic activity, or Bangladeshis living abroad who return for short-term visits.

## E. Social and Cultural Resources

56. **Population and Communities.** Dhaka is the capital and largest city in Bangladesh, and according to recent censuses the population has grown dramatically over the past 25 years, from 3.4 million in 1981 to 6.8 million in 1991, and 10.7 million in 2001 (Bangladesh Bureau of Statistics [BBS]). This is one of the fastest rates of population increase seen anywhere in the

world, and if growth continues at the same rate, by 2025 the City will accommodate over 22 million people. At present it is estimated that 55.8% of the population is male and 44.2% female, significantly different from the natural 1:1 ratio. There are around 2.24 million households in the City, so average household size is 4.78 persons, down from 6 per household in 1981.

57. Bangladesh is inhabited predominantly by a single ethnic group, Bengali, who constitute more than 98% of the population of the country. According to the 2001 census over 90% of the country is Muslim, and although this includes both Sunni and Shia, Sunnis are in the majority. Other religions are Hindu (9.2%), Buddhist (0.7%) and Christian (0.3%).

58. **Health Facilities.** Citizens of Dhaka suffer many of the diseases associated with poor sanitation, including dysentery, diarrhea, whooping cough, gastro-enteritis, and tuberculosis. There are a variety of medical facilities, both public and private-sector, covering general health care and specialized services (including cardiac and cholera hospitals, and eye hospitals). There are 16 public hospitals with more than 5,000 beds, and although patients are required to pay for the service, charges are significantly less than in the private sector, and some services are provided free to the poor.

59. **Educational Facilities.** Dhaka provides a large number of educational institutions, run by the public and private sectors. There are over 12,000 primary and secondary schools, several hundred colleges and technical institutes, and 52 universities (nine state-funded and 45 in the private sector). Generally, boys and girls are educated together, and there are no major differences in enrolment between the genders in schools, although boys outnumber girls in higher education. Current figures indicate that there are more than 5 million students studying in the City.

60. **Physical and Cultural Heritage.** There are several sites of cultural interest in Dhaka dating from various periods of the City's history. Most of the older sites are in the old part of the City and include:

- (i) The 12th century Dhakeshwari temple, which is the oldest Hindu temple in the City and is believed to be the origin of the name of Dhaka;
- (ii) Three sites from the Mughal period: the ruins of Bara Katra (enclosed quadrangle building) built on the banks of the Buriganga River in 1644; the smaller Chota Katra (palace), built nearby in 1663; and the three-storied Lalbagh Fort, built in 1678;
- (iii) The 18th century Star Mosque, which has many interesting architectural features including a three domed (Mughal style) structure, mosaic floors and decorated walls; and
- (iv) Other mosques such as: The Baitul Mukarram, the largest mosque in the city; the Chawkbazar Masjid built in 1676; the seven-domed Mughal Satgambuj mosque built in the 17th century; and Begum Bazar mosque built in 1701.

61. **Indigenous Peoples.** There are no indigenous people identified in the mentioned DMAs.

## **F. Site Specific Existing Condition of 16 DMAs in the Project Area**

62. Table 3 provides description of the 16 DMAs covered by Package No. ICB 2.7.

**Table 3: Description of Each DMA under Package No. ICB 02.7**

	<b>DMA</b>	<b>Existing Conditions</b>
1.	601	DMA 601 is located to the south of a water course which forms the northerly boundary. The area comprises newly built residential blocks in orderly developments. There is little industry and only low level commerce. The area has been infilled in recent years and is low lying, especially to the south. Sub surface water may be present as a result. There are 6 production tube wells in the area which is well served.
2.	602	The area is low lying and has been substantially developed since the satellite imagery presented in the preliminary design. The contractor shall not, initially, rehabilitate the area, which should be subject of a detailed leak detection programme as detailed in these requirements.
3.	603	The area is a fragmented and unplanned area with significant levels of informal slum housing. There area is also very low lying which results in large areas of water surrounding the developed areas
4.	604	The area is well developed with low lying areas to the East. The area is well structured and consists predominantly of long straight pipelines.
5.	605	This area is in the south eastern part of the zone which is largely peri-urban in nature. The network serves some outlying districts. Some informal settlements are present in the area.
6.	606	This is a large area of unplanned residential housing and basic industrial units.
7.	607	The area is just beside DMA 603 and unplanned area with significant levels of informal slum housing. It is also very low lying which results in large areas of water surrounding the developed areas.
8.	608	This is a planned but very densely developed area There are small slum areas to the north and east.
9.	609	The area is generally unplanned multi-storey housing with some informal slum settlements to the south.
10.	610	This is a planned but very densely developed area
11.	611	This is a large DMA. The area is a densely developed mix of planned and unplanned housing with informal slum settlements at many road sides, near Noor Masjif and on the west periphery bordering the water course / low lying land.
12.	612	DMA 612 is a formally planned area with significant residential housing as well government buildings. There is little informal settlement. To the north is an area of reclaimed land which has begun to be developed.
13.	613	This is a mixed area with government buildings to the south east and residential buildings in the remaining. The development of the area is unplanned and includes several areas of informal slum settlement. Any work close to the lines may require additional permission of the rail authorities.
14.	614	This is a mixed use DMA with residential housing in the east, north and west and park areas which include government buildings and a hospital in the south. There are small areas of slum along the railway to the north and along the main north south road.
15.	615	This area is mixed use with little residential housing. The areas to the east are government, military of other official buildings which are not currently served by DWASA. To the west is Ramna park which also includes officers' clubs, cathedral and other public buildings not served by DWASA.
16.	616	This area is not residential but houses many official offices as well as Dhaka University. Most public buildings are not served by the DWASA network and the area is largely a network of transmission mains to export water to other DMAs.

## V. ANTICIPATED IMPACTS AND MITIGATION MEASURES

### A. Magnitude and Significance of Impacts

63. The implementation of the project will affect most of the city as branches of the distribution network are located in most roads and streets and the construction process will continue for about 2.5 years. However, the construction work is in fact not expected to cause major negative impacts. This is because:

- (i) Most network construction will be conducted by small teams working on short lengths at a time so most impacts will be localized and short in duration; and
- (ii) Because of the large population and overcrowded conditions in much of the City, the environment of Dhaka is heavily degraded, and contains few sensitive features.

64. **Methodology.** Issues for consideration have been raised by the following means: (i) input from interested and affected parties; (ii) desktop research of information relevant to the proposed project; (iii) site visit and professional assessment by environment specialist engaged by the implementing agency; and (iv) evaluation of proposed design scope and potential impacts based on the environment specialist's past experience. Categorization of the project and formulation of mitigation measures have been guided by ADB's REA Checklist for Water Supply (Appendix 1) and ADB SPS 2009.

## B. Planning and Design Phase

65. Outline design of ICB 02.7 was done by Design and Management Consultants in 2010. Based on the on-going packages and DWASA experience in implementing similar projects, planning principles and design considerations have been reviewed and incorporated into the site planning process whenever possible (salient design features are presented in Table 4). The outline design of DMA 601 & 607 has been updated incorporating information gathered through detailed survey. The updated models were checked for performance of the system for existing and future (2030) scenario. Considering the rapidly depleting groundwater level and keeping consistency with future water supply plan of DWASA, surface water from transmission main was considered for future water source. To overcome the possible risks and uncertainties, at least one inter-DMA connection chamber with valves is considered as contingency plans to satisfy consumer needs in the event of key facility fails. To ensure the robustness of the models risk analysis, sensitivity analysis, surge analysis, etc. were carried out and optimized the models until they were satisfactory. As a result, some measures and design criteria have already been included in the package. This means that the impacts and their significance have already been reduced. To minimize traffic disturbance and public life hazards, trenchless technologies is being used wherever possible for laying pipes during implementation of the package. The introduction of trenchless technologies requires the use of High-Density Polyethylene (HDPE) pipe which satisfies project requirement as pipe material, design life, tensile strength, joint strength etc.

66. The package is being implemented through a design-built contract, i.e. the civil works contractors also prepare the detail designs. Thus the contractors conduct detailed survey of the project area, update the initial designs with additional information obtained from survey; and submit the detailed design package and expected work methodologies for each DMA.

**Table 4: Environment-Related Design Features of the Package**

Activity	Design Consideration
Contractor's responsibility	The contractors shall: - Be familiar with the present traffic congestion of Dhaka city, rules and regulation of Dhaka City Corporation (DCC) for preparation of road cutting plans before execution of works; - Arrange for temporary water supply to every household as and when their water supply is disconnected or disrupted; - Protect all underground and overground utility services viz. telephone, electricity, gas, sewer, drainage, etc. from damage during execution of the contract.
Pipe replacement rehabilitation, <sup>11</sup> and network extension <sup>12</sup>	- In all cases, AC pipes shall be replaced. Existing AC pipes, where intact, shall be left in-situ and not disturbed. Where the AC pipe is damaged and where there is a risk of asbestos particles becoming airborne, the contractor shall follow all necessary

<sup>11</sup> The term pipe replacement is understood to mean that the existing pipe will be replaced, either by the traditional open trench method, where the existing pipe will be abandoned and a new pipe will be installed or by pipe bursting,

Activity	Design Consideration
	<p>procedures, guidelines and laws as laid out locally or by this EMP to contain and remove hazardous material.</p> <ul style="list-style-type: none"> <li>- The network expansion into different residential / industrial areas will be through trenchless or conventional trenching methods whereby the pipelines will be laid with a minimum cover depth of 1.0 metres.</li> </ul>
Working hours and times	<ul style="list-style-type: none"> <li>- All work in major roads and on minor roads that are heavily used by traffic will only be permitted at night between 7:00 pm and 7:00 am.</li> <li>- All the minor roads and alley with less traffic may be considered for both day and night working provided alternative passageway can be maintained.</li> </ul>
Road cutting <sup>13</sup>	<ul style="list-style-type: none"> <li>- Unnecessary road cutting should be avoided.</li> <li>- The contractor has to take all necessary safeguards to avoid accidents at site, prevent loss/damage to all existing utilities like pipelines, telephone/gas/electric cables, poles etc and any government or private property during the contract period.</li> <li>- DWASA will apply for the road cutting permission and the contractor shall give full effort and cost for collection of road cutting permission for required days. Therefore, the road cutting plans necessary for the application must be prepared by the contractor.</li> <li>- No temporary or permanent works must proceed before the design and drawings are approved by the Project Manager and road cutting permission obtained from DCC by PMU</li> <li>- The contractor shall prepare a traffic management scheme (road closure program or diversions) and incorporate detail of traffic diversions and pedestrian routes, all traffic signs (for the regulation and for information) and road markings shall be ensured prior to start of road cutting.</li> </ul>
Road excavation	<ul style="list-style-type: none"> <li>- All excavations shall be done to the minimum dimension as required for safety and working facility</li> <li>- The excavation must be carried out in the most expeditious and efficient manner.</li> <li>- The excavation shall be executed in such manner, that the contractor does not damage or interfere with existing services or structures. If damage or interference is so caused the contractor shall make arrangements with the supply and/or building owner to execute the repairs at the contractor's own cost.</li> <li>- All trench and pit excavations and other work shall be carried out during night time and within the limits of any existing road area shall be completed as rapidly as possible and, in the case of roads capable of carrying two or more lanes of traffic, not more than one half of the width of the carriage way shall be obstructed at any one time. In single lane roads, the contractor shall programme his work in such a manner that the minimum inconvenience is caused to those persons who have reasonable grounds for using the road.</li> <li>- Road drains and channels shall be kept free from obstructions at all times.</li> <li>- In case of excavation in VIP and other large roads, the trenches and pits maybe need to be covered by steel plates to allow traffic to pass during non-working periods. The contractor must liaise with the DCC and the responsible police to familiarize themselves and adhere to such rules. All costs involved to adhere to such rules shall be borne by the contractor.</li> <li>- Pits and trenches not backfilled at end of a night shift, the excavation must be covered with steel plates and in alleys with wooden plates.</li> <li>- It is preferable that trench excavation along roads be located in footpaths or verges adjacent to the road rather than in the carriage way itself. Trench excavation shall wherever practicable be carried out in such a way that every part of the excavation is at least 0.5m clear of existing edges of the carriage way.</li> <li>- Where trench excavation or any other part of the works obstructs any footpath or right-</li> </ul>

where the existing pipe will be used as a host pipe which will be cut open, expanded and a new pipe will be installed inside the old pipe.

<sup>12</sup> The term pipe extension is understood to mean the laying of a new pipe where no distribution pipes previously existed. Laying pipes in un-served and underserved area and replacing spaghetti lines (bunch of small diameter coil pipes) with new reticulation pipe lines will be considered as extension work.

<sup>13</sup> Most of the roads are owned and maintained by DCC. Some narrow roads having width even less than 2 m are privately-owned.

Activity	Design Consideration
	of-way, the contractor shall provide, at his own cost, a temporary footpath around the obstruction to the satisfaction of the Project Manager. - The contractor shall have particular regard to the safety of pedestrian, livestock, and shall ensure that all open excavation, access routes and steep or loose slopes arising from the contractor's operations are adequately fenced and protected.
Trenchless pipe installation	- Pipes shall be installed by the horizontal directional drilling (HDD) methods where required. Should survey information indicate that the method is not feasible the contractor shall inform the Project Manager and gain prior approval for an alternative method or for open trench method. - Excavation material shall be removed from the conduit as the work progresses. No accumulation of excavated material within the conduit will be permitted. - The contractor shall provide sediment and erosion control measures in accordance with local environmental legislation. - The contractor shall supply portable mud tanks or construct temporary mud pits to contain excess drill fluids during construction. Spent drilling fluids and cuttings shall be confined to the entrance and exit pits. - The contractor shall take all necessary precautions to minimize the damage to the adjacent properties. Any drilling fluid that enters the pipe shall be removed by flushing or other suitable methods. - The contractor shall be responsible for cleanup and restoration - Pits excavated to permit connection of bored pipe shall be backfilled, and disturbed areas shall be restored to their original state or better. Sections of sidewalks, curbs, and gutters or other permanent improvements damaged during HDD operations shall be repaired or replaced at the contractor's expense.
Resettlement plan	The contractor shall: - Implement Resettlement Plans, prepared by DWASA. No civil works will begin until all compensation to affected persons is paid.
Preparation of catalogues, installation and O&M manuals	- The contractor shall supply catalogues and installation manuals for each type of pipes to DWASA at the time of submission the Operation and Maintenance manuals. - All catalogues and manuals shall be printed in the English language or accompanied by an English translation.

### C. Construction Phase

67. **Construction method.** Existing pipes are buried within roads in Dhaka City, and this practice will be continued by this project. Larger pipes (200 mm and above) are normally located in main roads, and smaller pipes (<200 mm) are in minor roads, and in most cases the pipeline is situated near the centre of the road.

68. All work in major roads and on minor roads that are heavily used by traffic will only be permitted at night between 7:00 pm and 7:00 am. All the minor roads and alley with less traffic may be considered for both day and night working provided alternative passageway can be maintained. In all cases the contractor shall take prior permission from DCC. Contractors in Dhaka are required to obtain permission from the police for construction work in roads. The work has to be conducted in amounts that can be completed in a single night, and the surface is reinstated for use in the morning.

69. Most of the pipe replacement/rehabilitation will be carried out by trenchless technology,<sup>14</sup> where a flexible plastic tube is inserted into an existing pipe and inflated to seal the inner surface. Small chambers are dug to open two ends of a pipe and a wire is inserted to pull through the plastic tube, which is expanded by air pressure and adheres to the inside of the

<sup>14</sup> This applies to all network construction in main roads, and an estimated 25% of the work in minor roads.

pipe. The only excavation is hand digging to build two small chambers (roughly 1.5 m<sup>3</sup>) per length, and the machinery is also small, involving a rotating drum for the wire and plastic liner, and an air compressor and water pump. This approach can also be used to install new pipes by drilling a horizontal tunnel and inserting the pipe, or by installing a tube inside a faulty pipe and inflating until the pipe bursts below ground, leaving a new pipe with a larger diameter and capacity. At some locations trenches will be built to remove leaking pipes and install replacements, and this will be done using backhoe diggers, supplemented by manual labor where necessary. Excavated soil will be loaded onto trucks and taken offsite for dumping, and sand for infilling will be brought in on trucks and stored on site. Pipes are normally covered by 1.2 m of soil, and a clearance of at least 100 mm is left between the pipe and each side of the trench to allow backfilling, so trenches will be relatively small, between 0.3 and 0.7 m wide and 1.4 and 1.8 m deep. DCC is responsible for re-applying the final asphalt surface to metalled roads, and this will be done after approximately 6 weeks, to allow settling of the compacted material.

70. Pipes will be of High Density Polyethylene HDPE (100-250 mm) and will be brought to site on trucks, offloaded manually or by crane, and positioned in the trench by crane or via a pipe-rig. After pipes have been joined, the trench will be backfilled with sand, and soil will be applied to the surface layer and compacted by hand-operated vibrating compactor.

71. Chambers for network valves for diameter 250mm and above and all bulk meters will be built in the trenches that are dug to install new pipes or at the entry and exit points for the trenchless work, so no separate excavation will be needed. Most chambers will be around 1.5 m<sup>3</sup> with concrete floors and brick sides, which will be built by hand by masons. Valves will be put in place by hand or via small cranes and will be attached to the pipe flanges, and each chamber will be closed by a removable steel manhole cover.

72. House connections will be provided when work is conducted on the distribution pipe in the vicinity, and short trenches will be dug between the pipe and each residence, and a short length of small-diameter high density polyethylene (HDPE) pipe will be attached. This will terminate at the boundary of the property with a meter and a small valve.

73. **Impacts on Physical Resources.** Since the detailed designs of DMA 605 & 608 have not been completed yet, the impacts on physical resources due to excavated materials and sand handling is presented only for DMA 601 & 607. The pipe installation work of 18,284.4 m out of total 24,596.7 m (74.33%) in DMA 601 will be completed using trenchless methods according to detailed design report. In DMA 607 the trenchless method will be used for only 4,309.0 m out of 16,356.9 m (26.34%) of pipe installation work. However, it was deemed during project preparation that most of the installation work would be done using trenchless methods. The construction using trenchless methods will not have major physical impacts as the only ground disturbance will be the excavation of chambers every 10 to 100 m for the entry and exit of the tunneling machinery and pipes. The use of this technology will generate waste material but since the contractor will be required to remove it quickly and dispose appropriately, this work will also not have major physical effects.

74. There will however be much greater physical disturbance from the installation of the remainder of the pipes, as this will require the construction of 18,360.20 m (DMA 601=6,312.3 m, DMA 607= 12,047.9 m) of trenches. If average trench dimensions are 0.5 x 1.6 m, then this work will excavate almost 14,688.16 m<sup>3</sup> of soil and stone in DMA 601 & 607 alone. After construction, approximately 25% of the trench will be occupied by the pipe, 50% by backfilled sand, and 25% by excavated soil replaced on top of the pipe. This means that over the project area as a whole,

a total of 7,344.08 m<sup>3</sup> of sand will be brought to site, 3,672.04 m<sup>3</sup> of soil will be replaced in the trenches, and 11,016.12 m<sup>3</sup> of waste soil and stone will be left over.

75. This presents a significant waste management issue, as this is a very large quantity of waste, which could not be dumped without causing physical impacts (on air quality, topography, soil quality, etc.) at the disposal site. There will also be quite large physical changes as a result of trench construction; and as the work will almost certainly be conducted in the dry season, there is also a lot of potential for the creation of dust (during excavation, storage and transportation of soil, and the importation of sand for infilling). Although most actions will be the responsibility of the contractors appointed to conduct this work, DWASA will also need to discuss the waste management issue in detail with DCC, to explore ways of reducing the amount of material to be dumped, by finding alternative beneficial uses.

76. The source of sand for the infilling will be determined by the contractors, and it is likely that this will be purchased from vendors who dredge sediment from the rivers for use in building and as infill in the floodplains to raise the level of building land. This is a major operation that has been underway for some considerable time, and removes very large quantities of sand from the river, without any apparent ill effects. This is probably because of the enormous amounts of sediment that are carried by the rivers and deposited in the delta region, and it could be that the mining activity improves the flood retention capacity of the river and helps protect parts of the city from flooding. The 37,600 m<sup>3</sup> of sand that are required by this project represents a small fraction of the amount that is excavated annually, and will therefore not have significant additional impacts on the river beyond those of the operation as a whole.

77. Another physical impact that is commonly associated with large-scale excavation is the effect on local drainage patterns if surface- and ground- water collects in voids as they are being dug. This should however not be a problem in this case, given the relatively deep water table in Dhaka City, and the fact that the contractor will almost certainly conduct the excavation in the dry season to avoid difficult working conditions in the monsoon.

78. In overall terms, although a large volume of material will be removed during trench construction, a large volume of sand will be brought to the working sites, and a relatively large area will be affected, physical impacts are not expected to be significant. This is because:

- (i) The method of working, whereby small teams work on short lengths of the pipeline for a few days and complete the work before moving on to the next site, means that at each site the effects will be mainly localized and short in duration;
- (ii) Physical impacts will be mainly temporary as trenches will be refilled and compacted after pipes are installed, and road surfaces will be re-covered with asphalt; and
- (iii) The design criteria and mitigation measures described in the Environmental Management Plan (EMP) will reduce those impacts with more wide-ranging implications to acceptable levels.

79. **Impacts on Ecological Resources.** As most trenches and chambers for the trenchless works will be dug within roads, then there will not be any direct ecological impacts from construction of the network improvements. Contractors will however be required to ensure that no roadside trees are damaged or removed in the course of the work; and to mitigate any accidental losses, contractors will be required to plant and maintain two trees of the same species for every one that is removed.

80. The use of river sand for construction work can have ecological impacts by removing benthic invertebrates that provide food for fish, birds and other organisms, and destroying their habitats. However, these impacts will not be significant in this case because:

- (i) The amount of sediment removed for this project is a very small proportion of the total dredging operation;
- (ii) The large volumes of sediment carried by the river and the wide seasonal variations in flow mean that the river is a very dynamic ecosystem in which sediment erosion and accretion are part of the natural cycle, to which the invertebrate populations must adapt to survive;
- (iii) Sediments are a sink for many contaminants discharged into water bodies, so the dredging operation may provide some ecological benefit by reducing the overall pollution load.

81. **Impacts on Socio-Economic Resources.** The network improvement works will involve 40.95 km of pipe installation works in DMA 601 & DMA 607 in the streets of Dhaka City, which house very large numbers of shops, businesses, industries, and other economic activities. As the network is located in roadways, people and activities will undoubtedly be disturbed during the 2.5 years' construction period. However, it is not expected that this will result in major impacts on the economy of the city, or on the income of its businesses and citizens. This is because:

- (i) The installation of distribution pipes and reticulation pipes will be conducted by trenchless methods as much as possible, which require small-scale excavation at access points only, and will thus result in minimal disruption;
- (ii) Of the pipes that will require trenching, local by-laws require that works in roads are conducted at night, when most businesses are closed;
- (iii) Work will mainly be carried out on individual short lengths of the network, so each location will be affected for only a short time (an average of 5 days on the World Bank-funded 4th Dhaka Water Supply Project).

82. As all work will be conducted in existing roads and right-of-ways (ROWs) there will be no need to acquire land from private owners for the project, so there will be no resulting impacts on the income and assets of landowners or their tenants.

83. There can be economic impacts however if roads have to be closed for short periods and customers are unable to gain access to shops, or if trenches are constructed near the sides of roads, and customers are impeded by the presence of trenches, excavated material, workers and machinery. Although resulting losses in income will be small and short-lived, they can still be significant for small traders and other businesses that exist on low profit margins. A separate Resettlement Plan has been prepared for Package ICB No. 2.7 to examine the social and economic issues in more detail and provide appropriate mitigation where necessary. This establishes that, in addition to the mitigation measures in this IEE, owners and tenants of affected businesses will also be compensated to reduce the economic impact due to construction works.

84. Trenches will inevitably restrict traffic flows to an extent and roads may have to be closed on occasion. Although works in roads will be conducted at night, and individual streets will be affected for relatively short periods only, traffic impacts can still be significant, given the congestion problem that exists in Dhaka already. DWASA and the design consultants have

planned the work carefully by including in the design and specifications requiring the contractors to submit a traffic management plan for approval of the Project Manager.

**85. Impacts on Social and Cultural Resources.** When construction is conducted in residential areas, people may be disturbed by the noise of the construction activities and by dust during dry and windy weather, and trenches may impede access to houses for residents and their vehicles. In this case the fact that work will be conducted at night creates another potential problem as people may be disturbed by on-site lighting, and their sleep may be disrupted by noise. However, these impacts will not be greatly significant because:

- (i) Disturbance at most locations will last for a few days only;
- (ii) Background noise in much of Dhaka is high, even at night, so residents are adapted to a relatively high noise environment;
- (iii) People will be more willing to tolerate short-term temporary disturbance if they are aware of the benefits they will gain from an improved water supply.

**86.** DWASA will inform residents fully about the work, its duration and impacts, the mitigation measures, and the benefits of the completed scheme. In addition, officials in charge of facilities of social and cultural importance (e.g. schools, hospitals, mosques, museums, etc.) will be involved in stakeholder meetings so that they can be informed about the work in advance, and can bring specific concerns and issues to the attention of DWASA, if necessary.

**87.** A potentially more significant impact is the effect on people and communities if water supplies are closed down for extended periods when work is conducted on the network. This would be inconvenient in the short term, and there could be health risks if the water supply was unavailable for several successive days or longer. The package design and specifications require the contractors to plan the construction program to keep the cessation of water supplies to the minimum possible (in both area and duration), provide alternative potable water to affected households and businesses for the duration of the shut-down, liaise with affected persons to inform them of any cessation well in advance, and to ensure that they are provided with an alternative supply.

**88.** There is inevitably a safety risk when substantial construction such as this is conducted in an urban area, and strict precautions are needed to ensure the safety of both workers and citizens. Contractors will be required to produce and implement site Health and Safety (H&S) Plan.

**89.** An additional, particularly acute health risk presented by this work derives from the fact that some parts of the existing water supply system include pipes of AC, a material that can be carcinogenic if fibers are inhaled. There is therefore a significant health risk for workers and the public if these pipes are uncovered and damaged or cut accidentally, or deliberately to conduct the necessary pipeline refurbishment. This is in fact not such a major problem as might be expected, because:

- (i) There are only a small number of AC pipes in the existing water supply system but no AC pipes have been detected in DMA 601, 605, 607 & 608.
- (ii) These pipes are all in the old part of the city and their location is well known and marked on maps prepared by DWASA;
- (iii) The design of the project involves the replacement of these pipes and this can be done without removing or disturbing them, so all AC pipes will be left in situ.

90. Given the dangerous nature of this material, additional measures will still be established to protect the health of all parties in the event (however unlikely) that AC pipes are encountered in the course of the work. During the detailed design phase, the Management and Supervision Consultants (MSC) have developed a protocol to be applied in any instance that AC pipes are found, to ensure that appropriate action is taken. The protocol is based on the approach recommended by some internationally recognized organizations. The AC pipe protocol is attached in Appendix 9.

91. Given the scale of the project it is likely that large numbers of local people will obtain at least temporary socio-economic benefits, by gaining employment in the construction workforce, and thus raising their levels of income. These benefits can bring wider social gains if they are directed at vulnerable<sup>15</sup> groups. Contractors will therefore be given targets for the numbers of women and other vulnerable persons they should employ in their workforces, and DWASA will ensure that vulnerable persons are represented as legitimate project stakeholders in the various consultation forums and administrative committees established by the project. Creating a workforce from mainly local people will bring additional benefits by avoiding problems that can occur if workers are imported; including social difficulties in host communities and issues of health and sanitation in poorly serviced temporary camps.

#### **D. Operations and Maintenance Phase**

92. The main operations and maintenance (O&M) activities of the rehabilitated pipes will be detection and repair of leaks and pipe bursts. The generally flat topography and the usage of good quality pipes should mean that pipeline breaks are very rare, and that leaks are mainly limited to joints between pipes and areas where residents continue to attach their own illegal house connections. Leak repair work will be similar to the pipe-laying work as earlier explained. Trenches will be dug to reveal the leaking area and the faulty connection will be refitted, or the pipe will be removed and replaced if necessary.

93. The bulk meters will allow automatic computerized monitoring of amounts of water flowing through individual parts of the network, which will pinpoint areas where there are leaks and/or where water is being taken out of the system illegally. DWASA will visit such areas with audio devices to locate individual leaks, which will then be repaired in essentially the same way that the pipes were installed. Trenches will be dug to reveal the leaking area and the faulty connection will be re-fitted, or the pipe will be removed and replaced if necessary. If illegal connections are found these will be removed and the pipe will be re-sealed, or a new properly fitted connection with a meter will be provided.

94. **Impacts on Physical Resources.** Generally, the main risk to the physical environment of operating an improved water supply system is that increased abstraction of surface or groundwater will deplete the water resource. However, that will not be the case here, as there will be no additional abstraction. The increase in supply will be obtained from the refurbishment of the distribution network (which will significantly reduce system losses from leakage), and the installation of a new metering system (which will improve leak detection and cost recovery). This

---

<sup>15</sup> Vulnerable groups as those without legal title to land and other assets; households headed by single earner females, the elderly or disabled; indigenous peoples (based on ADB OM); and households with incomes that are below the poverty line

is expected to both improve the supply of water to the consumer and reduce the decline in groundwater from over-abstraction.

95. If trenches are dug to locate and repair leaks or remove and replace lengths of pipe or illegal house connections, the work will follow the same procedure that occurred when the infrastructure was improved. In this case soil and backfilled sand will be removed to expose the leaking junction or pipe, and if necessary a new pipe will be brought to site and replaced. The trench will then be refilled and re-compacted. This work should be very infrequent, and will affect individual small locations for short periods only (an average of a few hours for most repairs). Physical impacts will therefore be negligible. Work will not be conducted during rainfall so there will be no effect on drainage, and the removed material will be replaced in the trench so there will be no waste. There should also be no need to cover excavated material to prevent dust as it will have been wetted by the leaking water.

96. **Impacts on Ecological Resources.** The distribution network is located within roads, so any repairs will have no ecological impacts.

97. **Impacts on Socio-Economic Resources.** If network repairs are conducted in areas where there are shops or other commercial activities, these could lose some business while the repairs are conducted if access is difficult for customers. However, these will not be significant and will not need to be compensated, because repairs will be much smaller in scale than the original trenching works and much shorter in duration, so any losses will be at the level of normal day-to-day fluctuations in business income.

98. **Impacts on Social and Cultural Resources.** If network repairs are conducted in residential areas people may be disturbed by construction noise, and there could be some interruption of access to houses and locations of social and cultural importance (such as mosques, schools and hospitals) by the trenches and excavated soil. However, these impacts should also not be significant because of the short-term and infrequent nature of the works.

99. DWASA (and the contractors during the defects liability period) will operate the same kinds of H&S procedures as used in the construction phase to protect workers and the public. This will include application of the asbestos protocol if any AC pipes are encountered, and prohibition of the use of AC pipes for any repair and maintenance work.

100. The citizens of the city will be the major beneficiaries of the improved water supply, as they will be provided with a constant supply of better quality water, piped into their homes. This should produce major improvements in the social capital of the city, and significant improvements in individual and community health and well-being. To augment these benefits, DWASA will conduct a public education and information campaign to raise awareness of the health risks of contaminated water and the continuing need to boil municipal water before consumption. Then diseases of poor sanitation, such as diarrhea and dysentery, will be greatly reduced.

101. People will then spend less on healthcare and lose fewer working days due to illness, so the economic conditions of individuals and the community as a whole should improve. There should be fewer deaths in infancy and at other stages of life, so the structure and well-being of families should also improve. The cultural resources of the city may also benefit, because if people are healthier and have more income, they should also have more time and money to spend on cultural pursuits.

## **E. Mitigation Measures**

102. There are no impacts that are significant or complex in nature, or that need an in-depth study to assess the impact. Thus, the project is will not cause significant adverse impacts. In addition to the mitigation measures and specifications already considered in the package design, the potential adverse impacts that are associated with construction and O&M can be mitigated to acceptable levels with the specific mitigation measures discussed in the EMP.

## **F. Cumulative Impact Assessment**

103. The cumulative impact assessment (CIA) examined the interaction between the project's residual effects (i.e., those effects that remain after mitigation measures have been applied) and those associated with other past, existing, and reasonably foreseeable future projects or activities. The interaction of residual effects associated with multiple projects and/or activities can result in cumulative impacts, both positive and negative. The project's potential cumulative effects were considered with respect to valued components (VCs) in environmental and socioeconomic categories, in four areas:

- (i) of any potential residual project effects that may occur incrementally over time;
- (ii) consideration of other known relevant projects or activities within the specified study area boundaries, even if not directly related to the project;
- (iii) potential overlapping impacts that may occur due to other developments, even if not directly related to the proposed project; and
- (iv) future developments that are reasonably foreseeable and sufficiently certain to proceed.

104. The project has identified the VCs as water quality, noise, traffic management, socio-economic and socio-community components, and human health. There are no foreseeable projects that will overlap with the project. The spatial boundary of the project is the area along the pipe alignment, existing right of ways, and building sites. The temporal boundary can be considered as the whole Dhaka City.

105. Given the water supply requirement in Dhaka will be met and the sources considered adequate, there are no significant cumulative impacts expected on the future water supply.

106. Air quality effects will occur during construction. Consequently, although emissions of common air contaminants and fugitive dust may be elevated in proximity to active work sites, this impact will be short-term and localized to the immediate vicinity of the alignment. Greenhouse gas (GHG) emissions may increase as a result of project activities (i.e., vehicle and equipment operation, concrete production, disposal of excavated material, landfilling of residual wastes). Given the project's relatively minor contribution to common air contaminants and GHG emissions during construction, the overall significance rating of both these potential residual effects is considered to be negligible.

107. Noise levels during construction in the immediate proximity of most work sites are expected to increase. The duration of this exposure will be relatively brief. This exposure represents a temporary, localized, adverse residual effect of low to moderate significance for affected receptors. While building damage due to ground vibrations is unlikely, there may be annoyance to spatially located receptors during construction. Noise levels associated with the project O&M will be largely imperceptible, as the buildings are located in relatively small sites within the city proper.

108. Land use/traffic management concerns will occur spatially during construction. Site-specific mitigation measures will be implemented to address temporary disruptions to land use and access, traffic delays and detours, parking modifications, and increased volumes of construction-related traffic. Traffic movement along the alignment will be improved once construction is completed. Since the project will be the rehabilitation of existing pipelines and a building to be constructed adjacent to existing water supply facilities, it will not conflict with existing or planned land use. However, following improvement in infrastructures and services, added residential developments, commercial, and business facilities and increased densities are expected to develop and enhance the project area. This can be considered a long-term cumulative benefit of the project.

109. Upon completion of the project, the sociocommunity will benefit from improved water supply system. This is considered a long-term cumulative benefit.

110. No adverse residual effects to human health will occur as a result of project construction or operation. While exposure to elevated noise levels and fugitive dust and common air pollutants will occur in proximity to project work sites during construction, due to their short-term, localized nature, these effects are expected to be minor and insignificant with no measurable effects on human health.

111. Therefore, the project will benefit the general public by contributing to the long-term improvement of water supply system and community livability in Dhaka City.

## **VI. INFORMATION DISCLOSURE, CONSULTATION, AND PARTICIPATION**

112. To ensure awareness and gain support from local community people towards project interventions, intensive population campaigns were conducted at different levels and category of people. The following methodologies were used for carrying out public information campaign and consultations in DMA 601. RPs of DMA 605, 607 & 608 have not been prepared yet.

### **A. Public Consultation Conducted (Planning and Design Stage)**

113. The public participation process included (i) identifying interested and affected parties (stakeholders); (ii) informing and providing the stakeholders with sufficient background and technical information regarding the proposed development; (iii) creating opportunities and mechanisms whereby they can participate and raise their viewpoints (issues, comments, and concerns) with regard to the proposed development; (iv) giving the stakeholders feedback on process findings and recommendations; and (v) ensuring compliance to process requirements with regards to the environmental and related legislation.

114. The following methodologies have been used for carrying out public consultation:

Local communities, individuals, and owners and employees of commercial establishments who are directly or indirectly affected were given priority while conducting public consultation.

- (i) Walk-through informal group consultations were held in the proposed project area.
- (ii) The local communities were informed through public consultation, with briefing on project interventions, including its benefits.
- (iii) The environmental concerns and suggestions made by the participants were listed, and discussed, and incorporated in the EMP.
- (iv) Various forms of informal public consultations (consultation through adhoc discussion-site) have been used to discuss the project activities.

**Table 5: Public Consultations Conducted in DMA 601**

SL No	Address	Participants Type	Purpose of Consultation	Key Issue Discussed	Interrogation on Design & Resettlement Plan
1	Nobala International Cadet Madrasa	Teachers, Officials, House Owners, WASA Representative, Guardians, Contractors Personnel & NGO Personnel etc.	Project Information Dissemination; Support Seeking and Showing Last Water Bill and House Connection Papers.	Project Description, How the user could assist contractors and keeping ready of the house connection papers.	Entitlement of APs; Implementation arrangement and Grievance Redress Mechanism incorporated in the RP based on the discussion.
2	Sovereign School & College	Teachers, Officials, House Owner's, Guardians, WASA Representative, Contractors Personnel, NGO Personnel etc.	Awareness Rising, Information Dissemination and Conflict management, Support for the Contractor.	Awareness Rising Indicator's, Grievance Raising Procedure, GRC formation Process and problem solution process	Implementation arrangement and Grievance Redress Mechanism incorporated in the RP based on the discussion
3	Momtaz Ideal School & College	Teachers, Officials, House Owner's, Guardians, WASA Representative, MSC Representative, Contractors Personnel and NGO Personnel etc.	Support Contractors, Managing Water Crisis, Gender Issues and Environmental and Safeguard Issues etc.	Project Implementation procedure and HH Connection & Pipe line Distribution issues, Environmental Issues and safeguard compliance.	Entitlement of APs; Implementation arrangement and Grievance Redress Mechanism incorporated in the RP based on the discussion.
4	Banosree Welfare Samitee Office	House Owner's, Govt. Officials, Businessmen, Welfare Samitee Member's, Local Elites, Civil Society Personnel, Contractors Personnel, MSC and the NGO Representatives.	Resettlement Plan disclosing Project Information Dissemination, Support Seeking for construction work, Grievance Redressing, Road Repair & maintenance and compensation for AP.	Background of the Project, Resettlement Plan, Entitlement, Institutional Arrangement, Grievance Redress Mechanism, Open Discussion and Support Seeking Areas.	Entitlement of APs; Implementation arrangement and Grievance Redress Mechanism incorporated in the RP based on the discussion.

115. A meeting on Project Information Disclosure for DMA 601 was held at the Banosree Welfare Samitee Office on 18/10/2016. House Owner's, Govt. Officials, Businessmen, Welfare Samitee Member's, Local Elites, Civil Society Personnel, Contractor's Personnel, MSC representatives and the NGO Representatives were present in the Meeting. The records of the project information disclosure meeting is shown in Appendix 3.

116. Key respondents included project-affected persons in DMA 601 who only include owners of houses/residences and commercial shops/establishments who will suffer temporary access disruptions during project implementation due to the laying of pipelines, shopkeepers/businessmen from the project area, and daily commuters consulted randomly. In addition to a number of informal consultations conducted regularly in the project corridor, house to house information dissemination, community level project information disclosure meeting on Resettlement Awareness and Support LIC's were conducted.

## **B. Future Consultation and Disclosure**

117. The IEE and other relevant documents will be made available at public locations in the city and posted on the DWASA and ADB websites. The consultation process will be continued and expanded during the project implementation through a nongovernment organization (NGO), to ensure stakeholders participate fully in project execution, as well as to implement a comprehensive information, education, and communication plan.

118. The public consultation and disclosure program with all interested and affected parties will remain a continuous process throughout the project implementation, and shall include the following:

- (i) **Consultations during construction phase:** (a) public meetings with affected communities to discuss and plan work programs and allow issues to be raised and addressed once construction has started; and (b) smaller-scale meetings to discuss and plan construction work with individual communities to reduce disturbance and other impacts, and to provide a mechanism through which stakeholders can participate in project monitoring and evaluation.
- (ii) **Project disclosure:** (a) public information campaigns to explain the project to the wider city population and prepare them for disruptions they may experience once construction is underway; (b) public disclosure meetings at key project stages to inform the public of progress and future plans, and to provide copies of summary documents in local language; (c) formal disclosure of completed project reports by making copies available at convenient locations in the study areas, and informing the public of their availability; and (d) providing a mechanism through which comments can be made.

119. For the benefit of the community, the summary of the IEE will be translated in the local language and made available at (i) DWASA office, (ii) area offices, and (iii) contractor's offices/campsites. It will be ensured that the hard copies of IEE are kept at places which are conveniently accessible to citizens, as a means to disclose the document and at the same time creating wider public awareness. An electronic version of the IEE will be placed in the official website of DWASA and the ADB website after approval of the IEE by ADB.

## **C. Involvement of NGOs, CBOs and Women's Organizations**

120. The NGO, Community Based Organizations (CBOs) representing women at different levels are actively involved in the project interventions in particular to the resettlement activities. Noted that the demand of the vulnerable people was well taken and addressed properly. NGOs will perform a number of key roles in the project, in particular:

- (i) An NGO have been appointed by the PMU to organize and implement the consultation and disclosure activities described above, and the various awareness raising campaigns;
- (ii) The PMU has appointed an NGO with experience of resettlement issues to implement Resettlement Plans in each hydraulic zone and distribute the entitlements;
- (iii) The concern consultant and resettlement expert engaged for monitoring the activities, with the help of the NGO, may fulfill the role of Training Coordinator in the PMU. They will organize training for DWASA staff, environment and resettlement cells, and CBOs in community level;
- (iv) NGOs have been appointed to assist the PMU and PCUs with other technical tasks, for example in conducting some of the resident surveys for the resettlement activities, where an established relationship with the communities is essential.

121. The main role of CBOs and organizations representing women and other vulnerable groups will be to represent the interests of their members in dealings with the program proponents, in particular the PMU and PCUs and also the contractors. These organizations will be registered stakeholders and will thus be involved in the various consultation and disclosure activities. Together with NGOs they will be assured of representation in the various committees and other forums that are established to plan and implement the program and monitor its progress. As a further safeguard to ensure their representation and involvement key positions on all committees will be reserved for women and vulnerable persons.

## **VII. GRIEVANCE REDRESS MECHANISM**

122. A project-specific grievance redress mechanism (GRM) has been established to receive, evaluate, and facilitate the resolution of AP's concerns, complaints, and grievances about the social and environmental performance at the level of the project. The GRM will aim to provide a time-bound and transparent mechanism to voice and resolve social and environmental concerns linked to the project.

123. DWASA has its own Grievance Redress Procedure (GRP), which it operates to address any dissatisfaction and complaints by residents regarding its activities. This is set out in the DWASA Resettlement Policy Framework (RPF), developed with World Bank assistance in January – March 2006 and approved by GoB in April 2006. This procedure will be applied to address any complaints or grievances during implementation of the DESWSP.

124. DWASA policy as set out in its RPF is to try to resolve complaints at project level through negotiations with community leaders and representatives of Affected Persons (AP). For this program these discussions will be conducted by the PIU, and will involve the AP and members of the relevant Zonal Level Coordination Committee (ZLCC), plus the Site Manager and Chief Engineer of the Construction Contractor if necessary. If a case cannot be resolved in this way it will be submitted to a Grievance Resolution Committee (GRC), led by the PMU Director, with two other members who are (i) a representative of the residents of the project area who is known to be a person of integrity and good judgment who commands respect, and

(ii) a representative of a local NGO or CBO (in this case the NGO implementing the Resettlement Plan).

125. The formation of GRC for DMA 605, 607 & 608 is under process and the following format will be followed for every DMA under ICB Package 02.7 of MODs Zone 6. The GRC of DMA 601 under ICB Package 02.7 is as below:

**Table 6: GRC of DMA 601**

#	Name	Designation at GRC	Institution	Designation
1	Executive Engineer , DESWSP	Convener	DWASA	EE, DESWSP
2	Md. Moktarul Alam	Member	NGO, SAMAHAR	Team Leader
3	Social and Safe guard Specialist	Member	CONSULTANT ( MSC)	Social and Safe guard Specialist
4	Assistant Engineer	Member	DESWSP DWASA	AE DESWSP
5	Safe Guard officer ( Social and Gender )	Member Secretary	DESWSP DWASA	Safe Guard Officer (S&G) DESWSP

126. The Project Coordinator convenes a meeting of the GRC in the project area, and conducts proceedings informally to reach an amicable settlement between the parties. The report of the committee is recorded in writing, and attested copies are provided to the parties involved. For this program the GRC will be required to meet and reach a decision within 14 days of receiving a complaint (verbally or in writing) from an AP or his representative. There will also be an appeals procedure where, if a person is dissatisfied with the ruling of the GRC, he or his representative may attend their next meeting to re-present the case. The committee will then re-consider the case in private, after which their decision is final. If the appellant is still not satisfied, he has the right to take his case to the public courts.

127. The PMU Resettlement Specialist will keep a record of all grievance cases and will examine these for recurring complaints and solutions and action to address these will be incorporated in subsequent RPs and IEEs. APs will be made aware of the GRM via the public consultation meetings, and will be informed of the outcome of cases at subsequent meetings. DWASA will also publish the outcome of cases on public notice-boards in each hydraulic area. If the aggrieved AP is not satisfied with the decision of the GRC, he/she has the right to refer his/her petition to the court of law.

128. All costs involved in resolving the complaints (meetings, consultations, communication, and information dissemination) will be borne by the PMU; cost estimates for grievance redress are included in resettlement cost estimates.

129. In the foreseeable event of GRM is not in a position to resolve the issue, the affected person can also use the ADB Accountability Mechanism (AM) through directly contacting (in writing) the Complaint Receiving Officer (CRO) at ADB Headquarters or the ADB Bangladesh Resident Mission (BRM). The complaint can be submitted in any of the official landgauges of ADB's DMCs. The ADB Accountability Mechanism information will be included in the PID to be distributed to the affected communities, as part of the project GRM.

130. Flow Chart of Grievance Redress Mechanism for ICB 02.7.

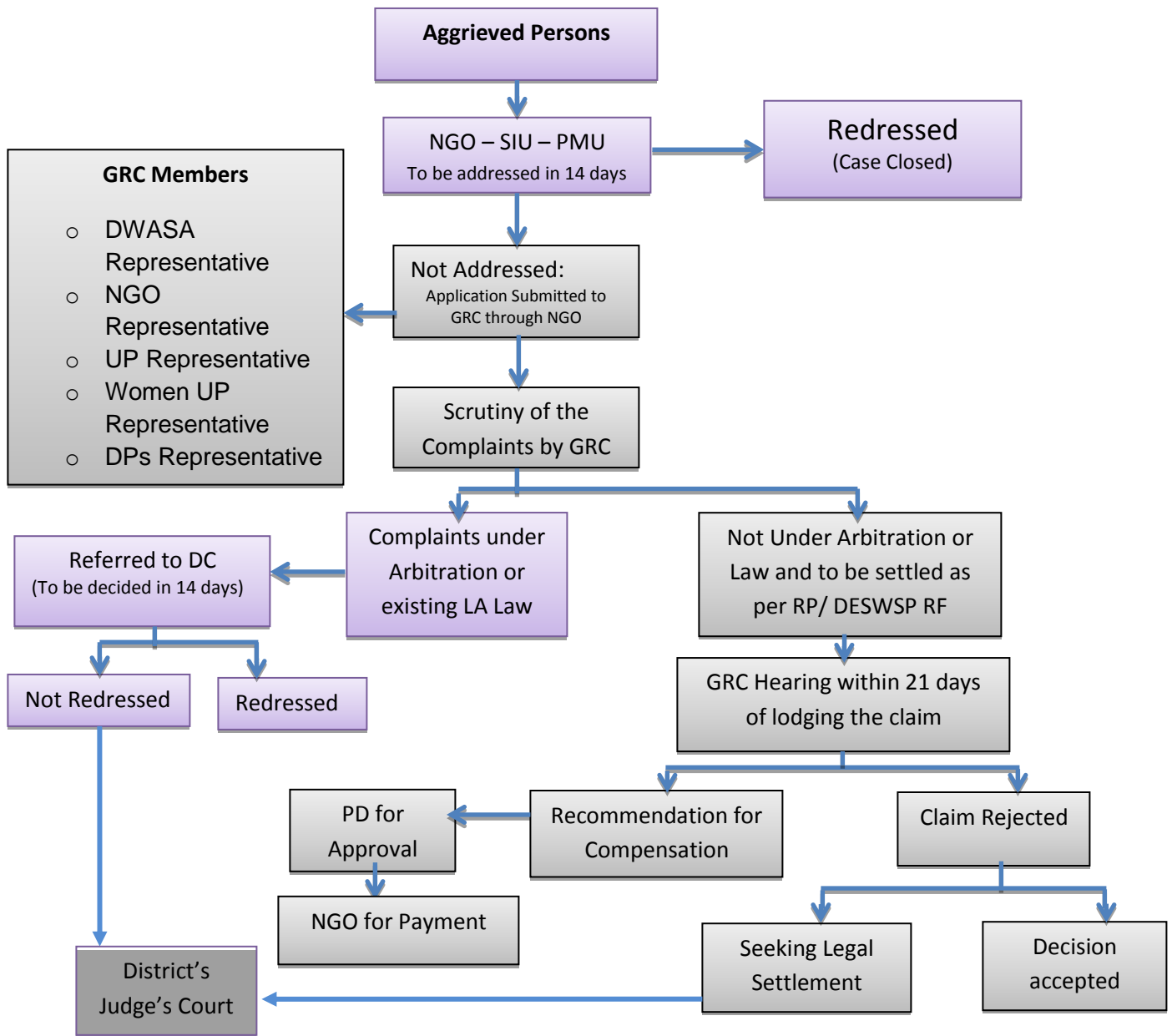

Source: Resettlement Plan (RP) of DMA 601

### VIII. ENVIRONMENTAL MANAGEMENT PLAN

131. The purpose of the environmental management plan (EMP) is to ensure that the activities are undertaken in a responsible, non-detrimental manner with the objectives of: (i) providing a proactive, feasible, and practical working tool to enable the measurement and monitoring of environmental performance on-site; (ii) guiding and controlling the implementation of findings and recommendations of the environmental assessment conducted for the project;

(iii) detailing specific actions deemed necessary to assist in mitigating the environmental impact of the project; and (iv) ensuring that safety recommendations are complied with.

132. The draft IEE was prepared during project preparation and now it has been updated based on the detailed designs of DMA 601 & 607 and draft model design of DMA 605 & 608. The updated IEE report will be submitted to ADB for review, approval, and disclosure prior to commencement of works. A copy of the EMP must be kept on work sites at all times. The EMP will be made binding on all contractors operating on the site and will be included in the contractual clauses. Non-compliance with, or any deviation from, the conditions set out in this document constitutes a failure in compliance.

## **A. Implementation Arrangement**

133. The project is being implemented through the Local Government Division (LGD) of the Ministry of Local Government, Rural Development and Cooperatives (MLGRDC). DWASA is both the EA responsible for the management, coordination and overall technical supervision of the program, and the IA responsible for supervising construction of the infrastructure and conducting the non-infrastructure elements.

134. DWASA has established a Project Management Unit (PMU), responsible for day-to-day management of the program, including tendering and selection of contractors, construction supervision, monitoring and evaluation, and compliance with safeguards policies. The PMU is headed by a full-time Project Director (PD) in the rank of DMD or Chief Engineer (CE). In addition, there are 2 (two) dedicated Deputy Project Directors (DPDs).

135. The PMU is being supported by the Management and Supervision Consultants (MSC), who design the infrastructure, manage tendering of contractors and supervise the construction process; and NGOs, who conduct public awareness campaigns. The PMU appoints individual construction contractors to build the infrastructure in one or more of the 16 hydraulic zones. Each contractor will be managed by the relevant Project Coordination Unit (PCU) and construction will be supervised by the MSC.

136. A PCU has been established in each of the four DWASA administrative (MODS) zones. Headed by the zonal Executive Engineer and staffed by PWSS personnel, the PCU is responsible for coordinating all activities at the local level in the zone, and engaging civil society.

137. DWASA is being assisted by an inter-ministerial Project Steering Committee (PSC), to provide policy guidance and coordination in the implementation of the program. The PSC meeting will be convened by LGD. Its membership will include the Managing Director, DWASA; Project Director of PMU; representative from Dhaka City Corporation; representative from the Economic Relations Division and the Finance Division of MoF; the Planning Commission; the Planning Monitoring and Evaluation Division; RAJUK (Capital Development Authority); LGED, Ministry of Environment and Forestry; and ADB representative as observer.

138. A Zonal Level Coordination Committee (ZLCC) will monitor implementation of the program at local level in each zone, and will report to the PSC.

139. Environmental issues will be coordinated by the MSC's Environmental EIA/IEE Expert and Environmental Monitoring Expert. The responsibilities of the MSC Environmental EIA/IEE Expert include: (i) carrying out EIA or IEE in accordance with the government rules and regulations and with the ADB requirements; and (ii) carry out environmental assessment of

alternative sites. The responsibilities of MSC's Environmental Monitoring Expert include, among others: (i) preparing EMPs based on IEEs; (ii) establishing a system to implement EMP to ensure compliance with ADB SPS and rules of the Government of Bangladesh; and (iii) disclosure of environmental information and interaction with stakeholders. He/she works closely with other specialist to ensure that guidelines specified in the EMP are reflected in project bidding documents and contracts. He/she will be responsible to prepare the report on environmental safeguard monitoring activities reports.

140. Resettlement issues are being coordinated by the MSC Resettlement Specialist, who prepares resettlement plans for each hydraulic zone as required by ADB SPS, following the Resettlement Framework established during program preparation. This specialist also coordinates the allocation of compensation and other entitlements, which is being distributed by PMU in each zone. The PMU is being assisted by the MSC Resettlement Expert. The resettlement plan of DMA 601 has been prepared and got approval from PMU. The RPs of other three DMAs (605,607 & 608) will be prepared soon. The working areas are planned and mostly covered by residential buildings where shops and hawkers are permitted to establish and run businesses. According to the project policy, the road width above 10 m will not come under consideration of resettlement compensation. Resettlement Awareness Team (RAT) of NGO SAMAHAR has completed the road measurement survey and joint verification survey of DMA 601 and it has been found that the widths of most of the roads are below 10 meters except 7 parts of Main Rampura – Banosree Road. 15 affected persons have been identified in Roads where the width is maximum 10 meters. In this DMA we have also determined all of the major and minor roads. NGO has collected information by interviewing each and every Vendors/Hawkers in the area under DMA 601 as per prescribed form of ADB and identified 15 (Fifteen) persons, (Vendors/Hawkers) for compensation. As per detailed survey report NGO recommend list of 15 (Fifteen) APs assessing compensation amount of their business loss or income loss. It was assessed that compensation on the basis of their daily average profit and proposed compensation for five days. In consequence NGO proposed to allocate BDT. 32500/- (Thirty Two Thousands Five Hundred) only as compensation against their 5 (five) days average profit or income.

141. **Contractor.** The contractor has an environment supervisor to (i) coordinate with MSC on updating the IEE/EMP based on detailed designs, and (ii) and ensure implementation of EMP during civil works.

142. Organizational procedures/institutional roles and responsibilities for the safeguards implementation are described in Table 7.

**Table 7: Institutional Roles and Responsibilities for Safeguards Implementation**

<b>Activities</b>	<b>Agency Responsible</b>
Disclosure of proposed project and anticipated social and environmental impacts on website	ADB DWASA
Disclosure of proposed project, social/environmental impacts, proposed entitlements/mitigation measures in local languages	DWASA
Disclosure of grievance redress mechanism/process	DWASA PMU MSC PCU ZLCC Nongovernment organization (NGO)
Finalization of sites and alignments	DWASA PMU

<b>Activities</b>	<b>Agency Responsible</b>
	MSC Contractors
Identification of roads for closure, existing utilities, road conditions	DWASA PMU MSC Contractors
Updating of safeguard documents (IEE and RP) based on detailed design	MSC with assistance from contractors and NGO
Review of updated RP/IEE and send to ADB for approval prior to contract award	DWASA PMU
Clearance and disclosure of updated safeguard documents	ADB DWASA
Conducting transect walks through road stretches to identify extent of impacts	MSC Contractor NGO
Conducting meetings at community/household level with affected persons (APs)	MSC Contractor NGO
Design/implementation of detailed measurement survey (DMS) <sup>16</sup> on roads identified for full/partial closure; identification of poor and vulnerable APs	MSC NGO
Computation of entitlements	DWASA PMU MSC
Categorization of APs for finalizing entitlements	MSC NGO
Conducting focus group discussions/meetings/consultations/workshops during DMS survey and updating safeguards documents	DWASA PMU MSC NGO
Finalizing entitlements and rehabilitation packages for all APs	DWASA PMU MSC NGO
Disclosure of final entitlements and rehabilitation packages	DWASA PMU MSC NGO
Delivery of entitlements/award of checks	DWASA PMU
Implementation of mitigation and rehabilitation measures	DWASA PMU MSC Contractor
Consultations with APs during rehabilitation activities	MSC Contractor NGO
Grievance redressal	DWASA PMU MSC NGO Contractor
Internal monitoring	DWASA PMU MSC

<sup>16</sup>Detailed measurement survey to be carried out during detailed design, to record and quantify resettlement impacts and entitled persons.

## B. Capacity Building

143. A training program has been developed to build the capability of PMU. This is being conducted by the Consultant.

144. PMU and the MSC will organize an induction course for the training of contractors, preparing them on:(i) EMP implementation, including environmental monitoring requirements related to mitigation measures; and (ii) taking immediate actions to remedy unexpected adverse impacts or ineffective mitigation measures found during the course of implementation. The contractor will be required to conduct environmental awareness and orientation of workers prior to deployment to work sites. The suggested outline of the training program is presented in Table 8.

**Table 8: Capacity Building and Training Program**

Description	Contents	Schedule	Participants	Remarks
<b>Program 1</b> Orientation workshop	<b>Module 1 – Orientation</b> ADB Safeguards Policy Statement Bangladeshi Environmental Laws and Regulations  <b>Module 2 – Environmental Assessment Process</b> ADB environmental process, identification of impacts and mitigation measures, formulation of an environmental management plan (EMP), implementation, and monitoring requirements Review of environmental assessment report to comply with ADB requirements Incorporation of EMP into the project design and contracts	1 day	DWASA officials involved in the project implementation  PMU MSC Contractors NGOs	An orientation workshop was conducted on ADB SPS by Environmental Specialist and Social Safeguard Specialist of ADB on 15 <sup>th</sup> November, 2015 during an ADB team visited Bangladesh. A demonstration of implementation procedure was conducted during their field visit to project location in Dhaka. The key issues regarding EMP implementation and Resettlement observed by the team in the field were discussed in the workshop.  A capacity building workshop on ADB & GoB Environmental Safeguard Requirement was conducted by MSC on 26 <sup>th</sup> June, 2016.
<b>Program 2</b> Orientation program/ workshop for contractors	Environmental issues during construction Implementation of EMP Monitoring of EMP implementation	1 day	PMU Contractors	Conducted by MSC on 9 <sup>th</sup> November,

Description	Contents	Schedule	Participants	Remarks
and supervisory staff	Reporting requirements			2016.
<b>Program 3</b> Experiences and best practices sharing	Experiences on EMP implementation – issues and challenges Best practices followed	1 day on a regular period to be determined by PMU and MSC	PMU MSC Contractors NGOs	To be conducted in January 2017.

### C. Environmental Management Action Plan

145. The EMP will guide the environmentally-sound construction of the project and ensure efficient lines of communication between the PMU, MSC, and contractors. The EMP identifies activities according to the following three phases: (i) site establishment and preliminary activities, including finalizing IEE/EMP; (ii) construction stage; and (iii) post-construction/operational stage. Table 9 outlines the mitigation measures and persons responsible for implementation and monitoring. The EMP has been updated by MSC, in close coordination with the contractors, during the detailed design stage of DMA 601, 605, 607 & 608. Updating of IEE/EMP will be a continuous process which will be done as detailed design of DMAs advances. Note that the final IEE/EMP should be reviewed and cleared by DWASA and ADB at time of detailed design of each DMA and prior to commencement of construction work.

146. **Environmental monitoring program.** A program of monitoring will be conducted: (i) to ensure that all parties take the specified action to provide the required mitigation, (ii) to assess whether the action has adequately protected the environment, and (iii) to determine whether any additional measures may be necessary. Most measures will be checked by simple observation, by checking of records, or by interviews with residents or workers. This will be coordinated by the PMU and MSC Environmental Management Expert (EMe). The EME will be responsible for all monitoring activities and reporting the results and conclusions to the PMU, and will recommend remedial action if measures are not being provided or are not protecting the environment effectively. The EME is being assisted by a fulltime Environmental Inspector who makes many of the routine observations at the various construction sites. Post-construction monitoring will be conducted by DWASA as part of their overall management of the operating infrastructure.

**Table 9: Environmental Mitigation Measures Action Plan**

Activity	Mitigation Measures	Responsible for Implementation	Responsible for Monitoring	Parameter to Monitor	Frequency of Monitoring	Guidelines/ Standards	Applicable for DMA 601, 605, 607, & 608	Not Applicable to DMA 601, 605, 607, & 608
<b>Planning and Design Phase</b>								
Contractor's responsibility	<ul style="list-style-type: none"> <li>- Be familiar with the present traffic congestion of Dhaka city, rules and regulation of Dhaka City Corporation (DCC) for preparation of road cutting plans before execution of works;</li> <li>- Arrange for temporary water supply to every household as and when their water supply is disconnected or disrupted;</li> <li>- Protect all underground and overground utility services viz. telephone, electricity, gas, sewer, drainage, etc. from damage during execution of the contract. Necessary compensation to be paid to the respective organization(s) as per their prevailing rules and regulations.</li> </ul>	Contractors	DWASA PMU MSC	<ul style="list-style-type: none"> <li>- Road Cutting Plan</li> <li>- Arrangement for temporary water supply</li> <li>- Disruption to utilities</li> </ul>	As required in the Program of Performance	Contract Provisions  EMP	√	
Pipe replacement rehabilitation, <sup>17</sup> and network extension <sup>18</sup>	<ul style="list-style-type: none"> <li>- In all cases, AC pipes shall be replaced. Existing AC pipes, where intact, shall be left in-situ and not disturbed. Where the AC pipe is damaged and where there is a risk of asbestos particles becoming airborne, the contractor shall follow all necessary procedures, guidelines and laws as laid out locally or by this EMP to contain and remove hazardous</li> </ul>	Contractors	DWASA PMU MSC	<ul style="list-style-type: none"> <li>- Residual design life and proposed methods of repair</li> <li>- Inventory of AC pipes</li> </ul>	As required in the Program of Performance	Contract Provisions  EMP  AC Pipe Handling Protocol		√

<sup>17</sup>The term pipe replacement is understood to mean that the existing pipe will be replaced, either by the traditional open trench method, where the existing pipe will be abandoned and a new pipe will be installed or by pipe bursting, where the existing pipe will be used as a host pipe which will be cut open, expanded and a new pipe will be installed inside the old pipe.

<sup>18</sup> The term pipe extension is understood to mean the laying of a new pipe where no distribution pipes previously existed. Laying pipes in un-served and underserved area and replacing spaghetti lines (bunch of small diameter coil pipes) with new reticulation pipe lines will be considered as extension work.

**Table 9: Environmental Mitigation Measures Action Plan**

Activity	Mitigation Measures	Responsible for Implementation	Responsible for Monitoring	Parameter to Monitor	Frequency of Monitoring	Guidelines/ Standards	Applicable for DMA 601, 605, 607, & 608	Not Applicable to DMA 601, 605, 607, & 608
	material. - The network expansion into different residential / industrial areas will be through trenchless or conventional trenching methods whereby the pipelines will be laid with a minimum cover depth of 1.0 metres.							
Working hours and times	- All work in major roads and on minor roads that are heavily used by traffic will only be permitted at night between 7:00 pm and 7:00 am. - All the minor roads and alley with less traffic may be considered for both day and night working provided alternative passageway can be maintained.	Contractors	DWASA PMU MSC	Work hours	As required in the Program of Performance	- Contract Provisions - EMP	√	
Road cutting <sup>19</sup>	- Unnecessary road cutting should be avoided. - The contractor has to take all necessary safeguards to avoid accidents at site, prevent loss/damage to all existing utilities like pipelines, telephone/gas/electric cables, poles etc and any government or private property during the contract period. - DWASA will apply for the road cutting permission and the contractor shall give full effort and cost for collection of road cutting permission for required days. Therefore the road cutting plans necessary for the application must be prepared by the contractor.	Contractors for preparation of road cutting plan and payment for pavement restoration  Contractor for preparation and implementation of traffic management	DWASA PMU  DCC for issuance and monitoring of pavement compaction	- Road category along pipe alignments - Budget allocation for pavement restoration - Road cutting plan - Road cutting permission from DCC	Prior to start of civil works  After compaction and turn-over to DCC for pavement restoration	- Contract Provisions - EMP	√	

<sup>19</sup> Most of the roads are owned and maintained by DCC. Some narrow roads having width even less than 2 m are privately-owned.

Table 9: Environmental Mitigation Measures Action Plan

Activity	Mitigation Measures	Responsible for Implementation	Responsible for Monitoring	Parameter to Monitor	Frequency of Monitoring	Guidelines/ Standards	Applicable for DMA 601, 605, 607, & 608	Not Applicable to DMA 601, 605, 607, & 608
	<ul style="list-style-type: none"> <li>- No temporary or permanent works must proceed before the design and drawings are approved by the Project Manager and road cutting permission obtained from DCC by PMU.</li> <li>- The contractor shall prepare a traffic management scheme (road closure program or diversions) and incorporate detail of traffic diversions and pedestrian routes, all traffic signs (for the regulation and for information) and road markings shall be ensured prior to start of road cutting.</li> </ul>	<ul style="list-style-type: none"> <li>t scheme</li> <li>DWASA for the road cutting permit</li> <li>DCC for pavement restoration</li> </ul>						
Road excavation	<ul style="list-style-type: none"> <li>- All excavations shall be done to the minimum dimension as required for safety and working facility</li> <li>- The excavation shall not damage or interfere with existing services or structures. If damage or interference is so caused the contractor shall make arrangements with the supply and/or building owner to execute the repairs at the contractor's own cost.</li> <li>- All trench and pit excavations and other work shall be carried out during night time and within the limits of any existing road area shall be completed as rapidly as possible.</li> <li>- Road drains and channels shall be kept free from obstructions at all times.</li> <li>- In case of excavation in VIP and other large roads, the trenches and pits maybe need to be covered by steel plates to allow traffic to pass during non-working periods. The contractor must liaise with the DCC and the responsible police to</li> </ul>	<ul style="list-style-type: none"> <li>Contractors for preparation of road cutting plan and payment for pavement restoration</li> <li>Contractor for preparation and implementation of traffic management scheme</li> <li>DWASA for the road cutting permit</li> </ul>	<ul style="list-style-type: none"> <li>DWASA PMU</li> <li>DCC for issuance and monitoring of pavement compaction</li> </ul>	<ul style="list-style-type: none"> <li>- Road category along pipe alignments</li> <li>- Budget allocation for pavement restoration</li> <li>- Road cutting plan</li> <li>- Road cutting permission from DCC</li> </ul>	<ul style="list-style-type: none"> <li>Prior to start of civil works</li> <li>After compaction and turn-over to DCC for pavement restoration</li> </ul>	<ul style="list-style-type: none"> <li>- Bangladeshi Standards and Codes of Practice in their latest version, National Building code and Public Works Department (PWD) specification of the Govt.</li> <li>- Contract provisions</li> <li>- EMP</li> </ul>	√	

**Table 9: Environmental Mitigation Measures Action Plan**

Activity	Mitigation Measures	Responsible for Implementation	Responsible for Monitoring	Parameter to Monitor	Frequency of Monitoring	Guidelines/ Standards	Applicable for DMA 601, 605, 607, & 608	Not Applicable to DMA 601, 605, 607, & 608
	<p>familiarize themselves and adhere to such rules. All costs involved to adhere to such rules shall be borne by the contractor.</p> <ul style="list-style-type: none"> <li>- Pits and trenches not backfilled at end of a night shift, the excavation must be covered with steel plates and in alleys with wooden plates.</li> <li>- Where trench excavation or any other part of the works obstructs any footpath or right-of-way, the contractor shall provide, at his own cost, a temporary footpath around the obstruction to the satisfaction of the Project Manager.</li> <li>- The contractor shall have particular regard to the safety of pedestrian, livestock, and shall ensure that all open excavation, access routes and steep or loose slopes arising from the contractor's operations are adequately fenced and protected.</li> </ul>	DCC for pavement restoration						
Trenchless pipe installation	<ul style="list-style-type: none"> <li>- Pipes shall be installed by the horizontal directional drilling (HDD) methods where required. Should survey information indicate that the method is not feasible the contractor shall inform the Project Manager and gain prior approval for an alternative method or for open trench method.</li> <li>- Excavation material shall be removed from the conduit as the work progresses. No accumulation of excavated material within the conduit will be permitted.</li> <li>- The contractor shall provide sediment and erosion control</li> </ul>	Contractors	DWASA PMU MSC	<ul style="list-style-type: none"> <li>- Program of Performance</li> <li>- Pipe Bursting Plan</li> <li>- Plan for locating, exposing and re-connecting service connections</li> <li>- Proposed pit size and location</li> </ul>	As required in the Program of Performance	Contract provisions	√	

**Table 9: Environmental Mitigation Measures Action Plan**

Activity	Mitigation Measures	Responsible for Implementation	Responsible for Monitoring	Parameter to Monitor	Frequency of Monitoring	Guidelines/Standards	Applicable for DMA 601, 605, 607, & 608	Not Applicable to DMA 601, 605, 607, & 608
	<p>measures to prevent drilling fluid or borehole cuttings from entering water courses or other land adjacent to the site in accordance with local environmental legislation.</p> <ul style="list-style-type: none"> <li>- The contractor shall supply portable mud tanks or construct temporary mud pits to contain excess drill fluids during construction. Spent drilling fluids and cuttings shall be confined to the entrance and exit pits.</li> <li>- The contractor shall take all necessary precautions to minimize the damage to the adjacent properties. Any drilling fluid that enters the pipe shall be removed by flushing or other suitable methods.</li> <li>- The contractor shall be responsible for cleanup and restoration</li> <li>- Pits excavated to permit connection of bored pipe shall be backfilled, and disturbed areas shall be restored to their original state or better. Sections of sidewalks, curbs, and gutters or other permanent improvements damaged during HDD operations shall be repaired or replaced at the contractor's expense.</li> </ul>			<ul style="list-style-type: none"> <li>- Temporary water supply plan;</li> <li>- Plan for consumer notification.</li> <li>- Traffic management plan</li> </ul>				
Resettlement Plan	<ul style="list-style-type: none"> <li>- Implement Resettlement Plans, prepared by DWASA. No civil works will begin until all compensation to affected persons is paid.</li> </ul>	PMU DSC Contractors NGO	DWASA ADB	<ul style="list-style-type: none"> <li>- Number of affected person</li> <li>- Compensation to affected persons</li> <li>- Number</li> </ul>	Prior to start and during civil works	Resettlement Plan	√	

Table 9: Environmental Mitigation Measures Action Plan

Activity	Mitigation Measures	Responsible for Implementation	Responsible for Monitoring	Parameter to Monitor	Frequency of Monitoring	Guidelines/ Standards	Applicable for DMA 601, 605, 607, & 608	Not Applicable to DMA 601, 605, 607, & 608
				and type of information dissemination activities - Complaints from stakeholders				
Preparation of catalogues, installation and O&M manuals	- The contractor shall supply catalogues and installation manuals for each type of pipes to DWASA at the time of submission the Operation and Maintenance manuals. - All catalogues and manuals shall be printed in the English language or accompanied by an English translation.	Contractors	DWASA PMU MSC	- Program of Performance	Completion of civil works and decommissioning	- Contract provisions	√	
<b>Prior to Construction Phase</b>								
Preparation of final IEE/EMP	- Revise/update IEE/EMP based on detailed design - Submit to ADB for approval and disclosure	MSC to update  DWASA to submit to ADB	DWASA	- Detailed Design	After completion of detailed design and prior to start of civil works	ADB SPS EARF	√	
Environmental Monitoring Report	- Submit to ADB semi-annual environmental monitoring report	MSC to prepare  DWASA to submit to ADB	DWASA	- EMP - Contract provisions	Semi-annual	ADB SPS EARF IEE	√	
Legislation, permits, and agreements	- In all instances, DWASA, service providers, contractors, and consultants must remain in compliance with relevant local and national legislation. - A copy of the IEE must be kept on-site and disclosed in DWASA and ADB website	Contractor	PMU Environment Specialist and MSC Environment Monitoring Specialist	All applicable permits and approvals	Prior to award of contract and as necessary	- Locational Clearance - ECC - Road cutting permit	√	

**Table 9: Environmental Mitigation Measures Action Plan**

Activity	Mitigation Measures	Responsible for Implementation	Responsible for Monitoring	Parameter to Monitor	Frequency of Monitoring	Guidelines/ Standards	Applicable for DMA 601, 605, 607, & 608	Not Applicable to DMA 601, 605, 607, & 608
Education of site staff on general and environmental conduct <sup>20</sup>	<ul style="list-style-type: none"> <li>- Ensure that all site personnel have a basic level of environmental awareness training.</li> <li>- Staff operating equipment (such as excavators, loaders, etc.) shall be adequately trained and sensitized to any potential hazards associated with their task.</li> <li>- No operator shall be permitted to operate critical items of mechanical equipment without having been trained by the contractor.</li> <li>- All employees must undergo safety training.</li> </ul>	Contractor	PMU and MSC	Records of training	Prior to start of civil works and every new employee	Environmental management plan (capacity building)	√	
Safeguards supervisors	<ul style="list-style-type: none"> <li>- The contractor shall appoint one environment safeguard supervisor and one resettlement supervisor who will be responsible for assisting contractors in implementation of EMP, coordinating with the MSC environment management specialist and resettlement specialist, community liaison, consultations with interested/affected parties, reporting, and grievance redressal on a day-to-day basis.</li> </ul>	Contractor	Consultant	Hiring and actual work	As work progresses	Continuous work output and reporting records	√	
<b>Construction Phase</b>								
Safety, security and protection of the environment	<ul style="list-style-type: none"> <li>- Take all necessary precautions against pollution or interference with the supply or obstruction of the flow of, surface or underground water. These precautions shall include but not be limited to physical measures such as</li> </ul>	Contractors	DWASA PMU MSC MoEF	<ul style="list-style-type: none"> <li>- ECC provisions</li> <li>- Program of Performance</li> <li>- Waste Management</li> </ul>	<ul style="list-style-type: none"> <li>- As required in the Program of Performance</li> <li>- As work progresses</li> </ul>	<ul style="list-style-type: none"> <li>- ECC</li> <li>- Contract provisions</li> <li>- EMP</li> <li>- No complaints</li> </ul>	√	

<sup>20</sup> These points need to be made clear to all staff on-site before the project begins.

Table 9: Environmental Mitigation Measures Action Plan

Activity	Mitigation Measures	Responsible for Implementation	Responsible for Monitoring	Parameter to Monitor	Frequency of Monitoring	Guidelines/ Standards	Applicable for DMA 601, 605, 607, & 608	Not Applicable to DMA 601, 605, 607, & 608
	<p>earth bunds of adequate capacity around fuel, oil and solvent storage tanks and stores, oil and grease traps in drainage systems from workshops, vehicle and plant washing facilities and service and fuelling areas and kitchens</p> <ul style="list-style-type: none"> <li>- Establish sanitary solid and liquid waste disposal systems</li> <li>- Should any pollution arise, clean up the affected area immediately at his own cost and to the satisfaction of the Project Manager, and pay full compensation to any affected parties.</li> </ul>			<p>t Plan</p> <ul style="list-style-type: none"> <li>- Complaints from stakeholders</li> </ul>		received		
Protection of waterways	<ul style="list-style-type: none"> <li>- Every effort shall be made to ensure that any chemicals or hazardous substances do not contaminate the soil or water on-site.</li> <li>- Care must be taken to ensure that runoff from vehicle or plant washing does not enter the surface/ground water.</li> <li>- Site staff shall not be permitted to use any stream, river, other open water body, or natural water source adjacent to or within the designated site for the purposes of bathing, washing of clothing, or for any construction or related activities.</li> <li>- All concrete mixing must take place on a designated, impermeable surface.</li> <li>- No vehicles transporting concrete to the site may be washed on-site.</li> <li>- No vehicles transporting, placing, or compacting asphalt or any other bituminous product may be washed</li> </ul>	Contractor	DWASA MSC	<ul style="list-style-type: none"> <li>- ECC Provisions</li> <li>- Complaints from community</li> </ul>	As work progresses	<ul style="list-style-type: none"> <li>- No visible increase in turbidity and construction materials/wastes in surface water, any waterways, or drainage channels</li> <li>- Zero complaints from community</li> </ul>	√	

**Table 9: Environmental Mitigation Measures Action Plan**

Activity	Mitigation Measures	Responsible for Implementation	Responsible for Monitoring	Parameter to Monitor	Frequency of Monitoring	Guidelines/ Standards	Applicable for DMA 601, 605, 607, & 608	Not Applicable to DMA 601, 605, 607, & 608
	on-site. - All substances required for vehicle maintenance and repair must be stored in sealed containers until they can be disposed of removed from the site. - Hazardous substance/ materials are to be transported in sealed containers or bags.							
Construction of temporary structures (such as offices, storages, warehouses, scaffolding, etc.)	- Before commencement of the works on the sites submit to the Project Manager the drawings, where the proposed location and general arrangement or site construction survey of the contractor's office premises, workshops, storages, headquarters and other temporary constructions, necessary for adequate and easy execution of the contract. - Obtain own information about the access to all the parts of the sites and, if the contractor wants to use the roads, going through private properties, he shall complete all the formalities with the owners. - Ensure all necessary precautionary measures to avoid any accident due to traffic. He should ensure that for any activities/temporary or permanent structures, machineries and equipment, scaffolding or shoring should not obstruct free flow of surface runoff towards sewer system or drain. - Under no circumstances may open areas or the surrounding bushes be used as a toilet facility. - Encourage recycling and provide	Contractor	MSC	Location plan	- Prior to start of civil works - As work progresses	- Approved location plan - Construction method - No complaints received - No dumped wastes and litter at work sites at all times	√	

**Table 9: Environmental Mitigation Measures Action Plan**

Activity	Mitigation Measures	Responsible for Implementation	Responsible for Monitoring	Parameter to Monitor	Frequency of Monitoring	Guidelines/ Standards	Applicable for DMA 601, 605, 607, & 608	Not Applicable to DMA 601, 605, 607, & 608
	<p>separate waste receptacles for different types of wastes. Ensure that all litter is collected from the work and camp areas daily. Ensure camp and working areas are kept clean and tidy at all times.</p> <p>- No trees, shrubs, or groundcover may be removed or vegetation stripped without the prior permission of the engineer.</p> <hr/> <p>- The contractor shall submit a method statement and plans for the storage of hazardous materials (fuels, oils, and chemicals) and emergency procedures. - The contractor shall ensure the material safety data sheets of chemicals are posted in conspicuous areas.</p>							
Handling of surface water, flooding event, heavy downpour, etc. <sup>21</sup>	<p>- Protect the working area including pits, trenches, materials, machineries and equipment from any damage due to inundation by downpour.</p> <p>- Ensure not to make any congestion in the open drains or natural or artificial channels by any of his activity.</p> <p>- Take necessary measure to bring the site to the condition prevailing before the downpour without delay.</p>	Contractors	DWASA PMU MSC	<p>- Program of Performance</p> <p>- Bi-weekly 6 weeks running plan</p> <p>- On-site record book</p>	<p>- As required in the Program of Performance</p> <p>- As work progresses</p>	<p>- Contract Provisions</p> <p>- EMP</p>	√	

<sup>21</sup> Water logging problem exists during downpours and monsoon. Portions of roads may be flooded for prolonged periods after heavy downpours. The existing drainage facilities of Dhaka are insufficient. Only about 30% of the city's population is connected to the sewerage system. Dispose of wastewater through surface drains, or in low-lying areas, natural drains, or water bodies that find their way to storm sewers. During monsoon period with medium to heavy downpour the roads are inundated for 1-6 hours.

**Table 9: Environmental Mitigation Measures Action Plan**

Activity	Mitigation Measures	Responsible for Implementation	Responsible for Monitoring	Parameter to Monitor	Frequency of Monitoring	Guidelines/ Standards	Applicable for DMA 601, 605, 607, & 608	Not Applicable to DMA 601, 605, 607, & 608
	Necessary measure has to be taken so that storm water does not get into the newly installed pipelines. - Be particular in keeping updated weather forecast and maintain a record book at site in which weather condition is recorded.							
Handling of excavated soil	- Make own arrangements for the temporary storage of any excavated material. Haul away all excavated materials from the excavation site and deposit these in an area designated by DWASA. - Have regard to the working areas available to him for the construction of the pipeline particularly where this is located in roads or in other places to which the public has free access. - Be responsible for removal and disposal of any excavated material required for or not suitable for use as refilling as aforesaid or use elsewhere in the works. The cost of such removal of excess excavated earth shall be deemed to be included in the contract rates. - Hauling vehicles must always be present at the excavation site.	Contractors	DWASA PMU MSC	- Program of Performance - Bi-weekly 6 weeks running plan - On-site record book - Complaints from stakeholders	- Prior to start of civil works - As work progresses	- Contract Provisions - EMP	√	
Minimization of public disturbance	- Restrict his work to the sites allocated to him, and keep the sites accessible for inspection by competent authority at any time. - Ensure, as far as possible to minimize public disturbance and work during the nights. - Advance road signage indicating the road detour and alternative routes.	Contractors	DWASA PMU MSC	- Program of Performance - Inventory of utilities, signs and barriers - access to paths, steps, bridges,	- Prior to start of civil works (per pipe section) - During pipe laying/ replacement/ bursting - As work	- Contract provisions - EMP - No complaints received		

Table 9: Environmental Mitigation Measures Action Plan

Activity	Mitigation Measures	Responsible for Implementation	Responsible for Monitoring	Parameter to Monitor	Frequency of Monitoring	Guidelines/ Standards	Applicable for DMA 601, 605, 607, & 608	Not Applicable to DMA 601, 605, 607, & 608
	Provide sign boards for pedestrians to inform them of nature and duration of construction works and contact numbers for concerns/ complaints. - Provide adequately illuminated signs and barriers at night. Ensure these are clean, legible at all times and repositioned as necessary as the work progresses. - For the duration of the works, provide convenient access to paths, steps, bridges, crossings or drives for all entrances to property abutting the site and maintain them clear, tidy, and free from mud and objectionable matter.			crossings or drives for all entrances to property - Complaints from stakeholders and affected people - Records of disclosure and public consultations	progresses		√	
Warning of users prior to any disturbance in water supply	- Submit detailed work plan for the particular portion of the work to the Project Manager for approval. - Before setting out for the work, inform the inhabitants, businesses and consumers through appropriate means (bill board display, leaflet distribution, using colour papers announcement on radio and TV, publishing in the widely circulated daily newspapers) at least 7 days (or as directed by the Project Manager) before commencement of any work.	Contractors NGO	DWASA PMU MSC	- Program of Performance - Inventory of utilities - Liason with utilities owners and operators - Number and type of information dissemination activities - Complaints from stakeholders and affected people	- Prior to start of civil works (per pipe section) - During pipe laying/ replacement/ bursting	- Contract provisions - EMP - No complaints received - 7-day notice to public	√	
Maintaining water supply	- Plan and execute in such a way the water supply shall be kept in operation with maximum disruptions of one working day (12 hours)	Contractors	DWASA PMU MSC	- Program of Performance - Number of disconnecte	- Prior to start of civil works (per pipe section)	- Contract provisions - EMP - No		

**Table 9: Environmental Mitigation Measures Action Plan**

Activity	Mitigation Measures	Responsible for Implementation	Responsible for Monitoring	Parameter to Monitor	Frequency of Monitoring	Guidelines/ Standards	Applicable for DMA 601, 605, 607, & 608	Not Applicable to DMA 601, 605, 607, & 608
	<ul style="list-style-type: none"> <li>- Notify existing users about temporary disruption of water supply if unavoidable.</li> <li>- Provide with alternative water source to disconnected consumers to meet their daily requirement.</li> <li>- Ensure only clean water free from deleterious materials and of appropriate quality for its intended use is supplied.</li> <li>- In providing water, ensure that the rights of and supply to existing users are not affected either in quality, quantity or timing.</li> <li>- Inform the Project manager In the event of a dispute over the effect of the contractor's arrangements on the water supply of others.</li> </ul>			<ul style="list-style-type: none"> <li>d consumers</li> <li>- Quantity of supplied water to affected consumers</li> </ul>	<ul style="list-style-type: none"> <li>- During pipe laying/ replacement/ bursting</li> </ul>	<ul style="list-style-type: none"> <li>complaints received</li> </ul>	√	
Provision for security of the sites	<ul style="list-style-type: none"> <li>- Be responsible for guarding all utilities, plants equipment, material, etc. delivered on sites and for ensuring that all sign, lights, fences, etc. are in their proper place.</li> <li>- Provide, install and maintain suitable barriers and/or fences to protect the facilities, constructions camp, storage yard, existing facilities and construction and installation operations and to remove same when no longer required by DWASA, or at completion of the project.</li> </ul>	Contractors	DWASA PMU MSC	<ul style="list-style-type: none"> <li>- Program of Performance</li> <li>- Signs and barriers</li> <li>- Security measures in place</li> </ul>	<ul style="list-style-type: none"> <li>- Prior to start of civil works (per pipe section)</li> <li>- During pipe laying/ replacement/ bursting</li> <li>- As work progresses</li> </ul>	<ul style="list-style-type: none"> <li>- Contract provisions</li> <li>- EMP</li> <li>- No complaints received</li> </ul>	√	
Protection of trees and vegetation	<ul style="list-style-type: none"> <li>- Ensure that no trees or shrubs are felled or harmed except for those required to be cleared for execution of the works.</li> <li>- Ensure no tree shall be removed without the prior approval of the</li> </ul>	Contractors	DWASA PMU MSC MoEF	<ul style="list-style-type: none"> <li>- Program of Performance</li> <li>- Complaints from stakeholders</li> <li>- Number of</li> </ul>	<ul style="list-style-type: none"> <li>- As required in the Program of Performance</li> <li>- As work progresses</li> </ul>	<ul style="list-style-type: none"> <li>- ECC</li> <li>- Contract provisions</li> <li>- EMP</li> <li>- No complaints</li> </ul>		

**Table 9: Environmental Mitigation Measures Action Plan**

Activity	Mitigation Measures	Responsible for Implementation	Responsible for Monitoring	Parameter to Monitor	Frequency of Monitoring	Guidelines/ Standards	Applicable for DMA 601, 605, 607, & 608	Not Applicable to DMA 601, 605, 607, & 608
	Project Manager and any competent authorities. - Plant and maintain two trees of the same species for every one that is removed.			trees cut and planted		received - 100% survival of trees planted	√	
Use of wood as fuel	- Not use wood as a fuel for the execution of any part of the works, including but not limited to the heating of bitumen and bitumen mixtures and the manufacture of bricks for use in the works. - To the extent practicable, ensure that fuels other than wood are used for cooking, and water heating in all his camps and living accommodations.	Contractors	DWASA PMU MSC	- Program of Performance - Complaints from stakeholders	- As required in the Program of Performance - As work progresses	- Contract provisions - EMP - No complaints received	√	
Fire prevention	- Take all precautions necessary ensure that no buildings and supply utilities, etc. or vegetation along the line of the road outside the area of the permanent works is affected by fires arising from the execution of the works. - Follow any instructions of the competent authorities with respect to fire hazard when working in the vicinity of gas installations. - Immediately suppress if a fire occur in the natural vegetation or plantations adjacent to the road for any reason. - In areas of forest, shrub or plantation damaged by fire considered by the Project Manager to have been initiated by the contractor's staff or labour, replant and restore to the satisfaction of the Project Manager.	Contractors	DWASA PMU MSC	- Program of Performance - Number of fire occurrences	- As required in the Program of Performance - As work progresses	- Contract provisions - EMP - Zero fire occurrence	√	
Handling	- Submit to the Project Manager for	Contractors	DWASA	- Program of	- As required	- Contract		

**Table 9: Environmental Mitigation Measures Action Plan**

Activity	Mitigation Measures	Responsible for Implementation	Responsible for Monitoring	Parameter to Monitor	Frequency of Monitoring	Guidelines/ Standards	Applicable for DMA 601, 605, 607, & 608	Not Applicable to DMA 601, 605, 607, & 608
traffic and access	<p>approval a traffic management plan and detailed work plan showing activities on hourly basis.</p> <ul style="list-style-type: none"> <li>- Plan and conduct work in such a way that can be completed in 6-8 hours with as little as possible of traffic interruption, so all of this work (and probably most of the daytime work in minor roads) will be conducted by small teams of men, working on short lengths of the network (around 100 - 150 m) at a time.</li> <li>- Provide, erect and maintain barricades, signs, markings, flags, lights and flagmen as may be required for the information and protection of traffic. The flagmen shall be equipped with red and green flags and lanterns/lights.</li> <li>- Ensure barricades, signs, marking, and flags are of strong design. All barriers on roads and pedestrian areas shall be lit with warning lights during night time or when there is poor visibility.</li> <li>- Where the diversion or closure of any existing carriageway, walkway or public right of way is temporarily necessitated by the works, provide and maintain an alternative, which shall be operational before interference with the existing way.</li> <li>- Where ramps, temporary carriageways and walkways are required, they shall be provided and maintained to a standard suitable in all respects for the class or classes or</li> </ul>		PMU MSC	Performance - Traffic management plan - Lists and samples of warning signs and barricades	in the Program of Performance - As work progresses	provisions - EMP - No complaints received	√	

Table 9: Environmental Mitigation Measures Action Plan

Activity	Mitigation Measures	Responsible for Implementation	Responsible for Monitoring	Parameter to Monitor	Frequency of Monitoring	Guidelines/ Standards	Applicable for DMA 601, 605, 607, & 608	Not Applicable to DMA 601, 605, 607, & 608
	traffic or pedestrians. These must be kept usable by women, children, patients and disables.							
Minimizing noise level	<ul style="list-style-type: none"> <li>- Ensure noise level of the machineries and equipment must not exceed 70dB(A).</li> <li>- Use modern vehicles and machinery with standard adaptations to reduce noise and exhaust emissions, and ensure they are maintained to manufacturers' specifications.</li> <li>- Noise-generating equipment must be fitted with silencers.</li> <li>- If a worker is exposed to noise above a noise exposure limit, the contractor must investigate options for engineered noise control such as using low-noise excavators, jackhammers, drills, and power generators.</li> <li>- If it is not practicable to reduce noise levels to or below noise exposure limits, the contractor must post warning signs in the noise hazard areas. Workers in a posted noise hazard area must wear hearing protection.</li> </ul>	Contractors	DWASA PMU MSC	<ul style="list-style-type: none"> <li>- Complaints form community</li> <li>- Noise level monitoring record</li> </ul>	As work progresses	<ul style="list-style-type: none"> <li>- Bangladeshi Noise Standards</li> <li>- ECC Provisions</li> </ul>	√	
Mimimizing dust generation and air pollution	<ul style="list-style-type: none"> <li>- Limit dust by removing waste soil quickly, bringing sand to site only when necessary, covering and watering stockpiles, and covering soil and sand when carried on trucks.</li> <li>- Vehicles travelling to and from the construction site must adhere to speed limits so as to avoid producing excessive dust.</li> <li>- Access and other cleared surfaces,</li> </ul>	Contractors	DWASA PMU MSC	<ul style="list-style-type: none"> <li>- Program of Performance</li> <li>- Complaints from stakeholders</li> <li>- Vehicle emission testing records</li> </ul>	<ul style="list-style-type: none"> <li>- As required in the Program of Performance</li> <li>- As work progresses</li> </ul>	<ul style="list-style-type: none"> <li>- No visible increase in dust and particulate matters</li> <li>- No complaints received</li> </ul>	√	

Table 9: Environmental Mitigation Measures Action Plan

Activity	Mitigation Measures	Responsible for Implementation	Responsible for Monitoring	Parameter to Monitor	Frequency of Monitoring	Guidelines/ Standards	Applicable for DMA 601, 605, 607, & 608	Not Applicable to DMA 601, 605, 607, & 608
	including backfilled trenches, must be dampened whenever possible and especially in dry and windy conditions to avoid excessive dust. - Vehicles and machinery are to be kept in good working order and to meet manufacturer's specifications for safety, fuel consumption, etc. - The contractor is to have the equipment seen to as soon as possible should excessive emissions be observed.							
Protecting the community and facilities and locations of social and cultural importance (e.g. schools, hospitals, mosques, museums, etc.)	- Increase the workforce in sensitive areas to complete the work quickly. - Provide wooden walkways for pedestrians and metal sheets for vehicles to allow access across open trenches, where required. - Use directional down-facing lighting, fitted with effective shades at all times when working at night. - Give special attention to the screening of highly reflective materials on site. - Locate storage facilities and other temporary structures on site such that they have as little visual impact on local residents as possible. - Provide screening in areas where the visual environment is particularly important (e.g., along commercial routes) or privacy concerns for surrounding buildings exist. This can be in a form of shade cloth, temporary walls, or other suitable materials.	Contractors	DWASA PMU MSC	- Program of Performance - Bi-weekly 6 weeks running plan - On-site record book - Complaints from stakeholders - Grievance Redress Mechanism records	As required in the Program of Performance	- Contract Provisions - EMP - Zero complaints from the stakeholders	√	
Protecting health and	- Ensure continuing health and safety of the employees by producing and	Contractors	DWASA PMU	- Program of Performance	As required in the Program of	- Contract provisions		

Table 9: Environmental Mitigation Measures Action Plan

Activity	Mitigation Measures	Responsible for Implementation	Responsible for Monitoring	Parameter to Monitor	Frequency of Monitoring	Guidelines/ Standards	Applicable for DMA 601, 605, 607, & 608	Not Applicable to DMA 601, 605, 607, & 608
safety of workers	<p>applying a Health and Safety (H&amp;S) Plan for all working sites. The H&amp;S plans will include such measures as:</p> <ul style="list-style-type: none"> <li>(i) excluding the public from construction sites;</li> <li>(ii) ensuring that all workers are provided with and use appropriate Personal Protective Equipment;</li> <li>(iii) health and Safety Training for all site personnel;</li> <li>(iv) documented procedures to be followed for all site activities;</li> <li>(v) documented procedures to be followed for AC pipes; and</li> <li>(vi) accident reports and records.</li> </ul> <ul style="list-style-type: none"> <li>- Prior to the commencement of any hazardous operation, submit a Safety Method Statement to the Project Manager for his approval.</li> <li>- Ensure all workers have been suitably trained prior to commencing work and are to be adequately supervised whilst carrying it out.</li> <li>- Ensure all plant and equipment are suitable for the task to be undertaken and properly inspected/tested prior to being put into operation.</li> <li>- Maintain records and make reports concerning health, safety and welfare of persons, and damage to property. Take remedial action to prevent a recurrence of any accidents that may occur.</li> <li>- Provide hard hats, boots, other protective equipment and first aid box with all necessary medicines.</li> <li>- Train workers in safety issues.</li> </ul> <p>Provide suitable arrangements to cater</p>		MSC	<ul style="list-style-type: none"> <li>- Number of accidents</li> <li>- On-site Record</li> </ul>	Performance	<ul style="list-style-type: none"> <li>- EMP</li> <li>- Zero accident record</li> <li>- No complaints received</li> </ul>	√	

Table 9: Environmental Mitigation Measures Action Plan

Activity	Mitigation Measures	Responsible for Implementation	Responsible for Monitoring	Parameter to Monitor	Frequency of Monitoring	Guidelines/ Standards	Applicable for DMA 601, 605, 607, & 608	Not Applicable to DMA 601, 605, 607, & 608
	<p>for emergencies, including: first aid equipment (dressings, etc.); person(s) trained to administer first aid; communication with, and transport to, the nearest hospital with an accident / emergency department; monitoring equipment; rescue equipment; fire fighting equipment; and communication with nearest fire brigade station.</p> <p>- Provide adequate welfare facilities including, as a minimum, drinking water; toilets; washbasins with warm water, soap and towels; and clean/dry/warm area equipped with tables and chairs at which food can be eaten.</p>							
Replacement of asbestos cement (AC) pipes	<p>- Follow the protocol prepared by the design consultants to be applied in any instance that AC pipes are found.</p> <p>- Train all personnel (including manual laborers) to enable them to understand the dangers of AC pipes and to be able to recognize them in situ.</p> <p>- Inform the management immediately if AC pipes are encountered.</p> <p>- Remove all persons to a safe distance.</p> <p>- Delegate trained persons to deal with AC materials and require use of appropriate breathing apparatus and protective equipment</p> <hr/> <p>- Implement procedures for the safe removal and long-term disposal of all asbestos-containing material</p>	Contractor  MSC to develop AC pipes protocol	DWASA MSC	<p>- H&amp;S plan</p> <p>- Number of accidents and work-related injuries</p> <p>- Complaints from community</p>	As work progresses	<p>- Construction method</p> <p>- Detailed design documents</p> <p>- H&amp;S Plan</p> <p>- AC Protocol</p> <p>- Zero accident and work-related injuries</p>		√

Table 9: Environmental Mitigation Measures Action Plan

Activity	Mitigation Measures	Responsible for Implementation	Responsible for Monitoring	Parameter to Monitor	Frequency of Monitoring	Guidelines/ Standards	Applicable for DMA 601, 605, 607, & 608	Not Applicable to DMA 601, 605, 607, & 608
	encountered.							
Cultural and historical environment	<ul style="list-style-type: none"> <li>- All the staff and laborers of the contractor be informed about the possible items of historical or archaeological value, which include old stone foundations, tools, clayware, jewelry, remains, fossils, etc.</li> <li>- If something of this nature is uncovered, the Department of Archaeology shall be contacted and work shall be stopped immediately.</li> </ul>	Contractor	Consultant	Chance finds	As necessary	All chance finds shall be reported and turned over to the Department of Archaeology		√
<b>Post-construction phase (prior to turnover to DWASA)</b>								
Access	- All excavated roads shall be reinstated to original or better condition.	Contractor	Consultant	Road conditions	Prior to turnover	Pre-existing conditions	√	
Utilities and other existing infrastructure	<ul style="list-style-type: none"> <li>- All disrupted utilities restored</li> <li>- All affected structures rehabilitated/compensated</li> </ul>	Contractor	Consultant	All affected utilities	Immediately after civil works	All disrupted services restored	√	
Construction camps and storage areas	<ul style="list-style-type: none"> <li>- After construction work, all structures comprising the construction camp are to be removed from site or handed over to the property owner/community as per mutual agreement (if established on private/community land).</li> <li>- The area that previously housed the construction camp is to be checked for spills of substances such as oil, paint, etc. and these shall be cleaned up.</li> <li>- All hardened surfaces within the construction camp area shall be ripped, all imported materials removed, and the area shall be topsoiled and regrassed using the guidelines set out in the revegetation specification that forms part of this document.</li> </ul>	Contractor	Consultant	General condition of the areas	Prior to end of construction period/demobilization	Pre-existing condition	√	

**Table 9: Environmental Mitigation Measures Action Plan**

Activity	Mitigation Measures	Responsible for Implementation	Responsible for Monitoring	Parameter to Monitor	Frequency of Monitoring	Guidelines/Standards	Applicable for DMA 601, 605, 607, & 608	Not Applicable to DMA 601, 605, 607, & 608
	- The contractor must arrange the cancellation of all temporary services.							
Waste management	- All wastes shall be removed from the site and transported to a disposal site or as directed by the environment management specialist. Waybills proving disposal at each site shall be provided for the environment management specialist's inspection.	Contractor	Consultant	General condition of the areas	Prior to end of construction period/demobilization	Pre-existing condition	√	
<b>Operation and maintenance phase (including Defects Liability Period)</b>								
Detection and repair of leaks and pipe bursts	- Ensure leak detection and restoration time is minimized to the extent possible.	DWASA	DWASA	Number of reported leaks	As part of operations and maintenance of the improved system	Standards set by DWASA	√	

147. This discussion is written in relation to Table: 9 which describes environmental mitigation measures action plan in detail for package ICB 02.7. Additionally, extra two columns have been added to the table exclusively for DMAs 601, 605, 606 & 608, which will be implemented as 3<sup>rd</sup> phase, considering their applicability to each activity described in the table.

148. Implementation of the package under water supply improvement project will not create any significant adverse impacts on environment. However, most of the roads and streets where distribution networks located will be affected due to construction works for roughly two months, as per contractor's information, in each DMA. The contractor does not need to rehabilitate pipe network in these DMAs rather implementation of the DMAs will only be due to new construction. As a result, impacts caused by rehabilitation work are insignificant in that area but there will be impacts on surrounding environment due to new pipe installation works that involve nearly 50% of installation work will be done by open trenching method. The open trenching work will involve huge waste management work and will definitely cause some physical impacts on air, noise and soil topology during excavation, storage and transportation of soil, and the importation of sand for infilling. These impacts will be mitigated through some measures taken by contractors mentioned in Table 9. Since no AC pipes will be disturbed and will be left in situ where found, no significant mitigation measures will be required. However, if AC pipes would require for handling, AC pipes handling protocol, already developed by MSC, will be followed by the contractors.

149. The mitigation measures action plan in Table 9 has been formulated considering the impacts that might occur during implementation and post implementation of the package. The contractor must work accordingly to the mitigation measures action plan during implementation of the package.

#### **D. Reporting**

150. The supervision consultants will submit monthly monitoring reports to PMU reflecting performance of contractors in EMP implementation. The PMU safeguards unit will then submit semi-annual environmental monitoring reports to ADB for review and disclosure on ADB's website, as per ADB's safeguards policy and public communication policies. A sample monitoring template is in Appendix 4. The report should include update and progress of compliance with the ADB and government policies, and specifically on the progress of EMP implementation in relation to design and construction activities, grievances, and corrective actions.

#### **E. Environmental Costs**

151. The contractor's cost for site establishment, preliminary activities, construction, defect liability activities, and environmental mitigation measures related to EMP implementation during planning, design, and construction were incorporated into the contractual agreements and engineer's costs, which had been binding on him for implementation. The survey has been conducted by the contractor.

152. The operation phase mitigation measures are again of good operating practices, which will be the responsibility of the implementing agency (DWASA). All monitoring during the operation and maintenance phase will be conducted by DWASA; therefore, there are no additional costs.

153. The activities identified in the EMP mainly include site inspections and informal discussions with workers and local community, and this will be the responsibility of PMU with the assistance of MSC, costs of which are part of project management.

154. Table 10 presents the indicative cost to implement the EMP.

**Table 10: Indicative Cost for EMP Implementation**

Component	Description	Number	Cost per Unit (USD)	Cost (USD)	Source of Funds
Capacity building	(i) Orientation workshop for DWASA officials involved in the project implementation on ADB Safeguards Policy Statement, Bangladeshi Environmental Laws and Regulations, and environmental assessment process; (ii) induction course for the training of contractors, preparing them on EMP implementation and environmental monitoring requirements related to mitigation measures; and taking immediate actions to remedy unexpected adverse impacts or ineffective mitigation measures found during the course of implementation; and (iii) Lessons learned information sharing	Three modules, 1 day per module	\$500 per module	\$1,500	Covered under MSC contract
Dust suppression at work sites	Application of dust suppression measures during construction phase	As required	Contractor's liability	\$5,000	Covered under engineering design and construction – contractor
Baseline monitoring for noise	Once before start of construction works at specified corridor per work day	Two samples (daytime and nighttime) per work day	\$100 per sample	\$1,000	Covered under engineering design and construction – contractor
Surveys	Ongoing before start of construction work along pipe replacement corridors	Lumpsum	Contractor's liability	\$5,000	Covered under engineering design and cost –contractor

## IX. CONCLUSION AND RECOMMENDATION

155. The process described in this document has assessed the potential environmental impacts of all elements of the project in Dhaka City. All potential impacts were identified in relation to pre-construction, construction, and operation phases.

156. Planning principles and design considerations have been reviewed and incorporated into the site planning process whenever possible; thus, environmental impacts as being due to the project design or location were not significant. However, the social impacts (access disruptions) due to construction activities are unavoidable, as the residential and commercial establishments exist along the project corridor. A resettlement plan has been developed in accordance with ADB SPS 2009 and Bangladeshi laws and regulations.

157. The EMP will assist the PMU, MSC, and contractors in mitigating the environmental impacts, and guide them in the environmentally sound execution of the proposed project. The EMP will also ensure efficient lines of communication between the implementing agency, project management unit, and contractors.

158. The public participation processes undertaken during project design ensured stakeholders are engaged during the preparation of the IEE. The planned information disclosure measures and process for carrying out consultation with affected people will facilitate their participation during project implementation.

159. The project's grievance redressal mechanism will provide the citizens with a platform for redressal of their grievances, and describes the informal and formal channels, time frame, and mechanisms for resolving complaints about environmental performance.

160. A copy of the EMP shall be kept on-site during the construction period at all times. The EMP shall be made binding on all contractors operating on the site, and will be included in the contractual clauses. Non-compliance with, or any deviation from, the conditions set out in this document shall constitute a failure in compliance.

161. The project will benefit the general public by contributing to the long-term improvement of water supply system and community livability in Dhaka City. The potential adverse environmental impacts are mainly related to the construction period, which can be minimized by the mitigating measures and environmentally sound engineering and construction practices.

162. Therefore, as per ADB SPS, the project is classified as environmental category B and does not require further environmental impact assessment.

## APPENDIX 1: ADB REA CHECKLIST

Screening Questions	Yes	No	Remarks
<b>A. Project siting</b> Is the project area...			
• Densely populated?	✓		The population distribution shows that the project area is densely populated.
• Heavy with development activities? Adjacent to or within any environmentally sensitive areas?		✓	No water supply project components are within locations in or near sensitive and valuable ecosystems, including protected areas and forests.
• Cultural heritage site		✓	
• Protected area		✓	
• Wetland		✓	
• Mangrove		✓	
• Estuarine		✓	
• Buffer zone of protected area		✓	
• Special area for protecting biodiversity		✓	
• Bay		✓	
<b>B. Potential environmental impacts</b> Will the project cause...			
• Pollution of raw water supply from upstream wastewater discharge from communities, industries, agriculture, and soil erosion runoff?		✓	The network in Dhaka is currently supplied by limited surface water (18%) and ground water from tubewells (82%) across the city. Surface water use (Buriganga and Sitalakhya Rivers) is limited due to the lack of suitable, non-polluted water. The Ministry of Environment and Forests estimates that 80% of the sewage produced by the 15 million people in Dhaka and surrounding areas; and effluent from 7,000 industries enter the rivers untreated (Dhaka Environment Programme, 2005).
• Impairment of historical/cultural monuments/areas and loss/damage to these sites?		✓	Not applicable
• Hazard of land subsidence caused by excessive groundwater pumping?		✓	Not applicable
• Social conflicts arising from displacement of communities?		✓	No displacement of communities is required in this project.
• Conflicts in abstraction of raw water for water supply with other beneficial water uses for surface and ground waters?		✓	Water quantity is sufficient and there is no additional abstraction.
• Unsatisfactory raw water supply (e.g., excessive pathogens or mineral constituents)?		✓	Raw water is being treated prior to distribution. Water quality of treated water complies with the Bangladesh standards for drinking water.
• Delivery of unsafe water to distribution system?		✓	The project will provide treated water through new pipes to prevent leakages and contamination.
• Inadequate protection of intake works or wells, leading to pollution of water supply?		✓	The intake will be secured and will be accessible only to authorized persons. It will also be regularly monitored to ensure only treated and unpolluted water are distributed.
• Overpumping of groundwater, leading to salinization and		✓	Not applicable

Screening Questions	Yes	No	Remarks
ground subsidence?			
<ul style="list-style-type: none"> <li>Excessive algal growth in storage reservoir?</li> </ul>		✓	Not anticipated. The storage reservoirs are fully enclosed structures. In addition, treated water will only be stored for a short period of time.
<ul style="list-style-type: none"> <li>Increase in production of sewage beyond capabilities of community facilities?</li> </ul>		✓	Sewerage system improvements are being undertaken by DWASA.
<ul style="list-style-type: none"> <li>Inadequate disposal of sludge from water treatment plants?</li> </ul>		✓	Not applicable
<ul style="list-style-type: none"> <li>Inadequate buffer zone around pumping and treatment plants to alleviate noise and other possible nuisances and protect facilities?</li> </ul>		✓	Not applicable
<ul style="list-style-type: none"> <li>Impairments associated with transmission lines and access roads?</li> </ul>	✓		Anticipated during construction activities. However, impacts are temporary and short in duration. The EMP includes measures to mitigate the impacts.
<ul style="list-style-type: none"> <li>Health hazards arising from inadequate design of facilities for receiving, storing, and handling chlorine and other hazardous chemicals?</li> </ul>		✓	Not applicable
<ul style="list-style-type: none"> <li>Health and safety hazards to workers from handling and management of chlorine used for disinfection, other contaminants, and biological and physical hazards during project construction and operation?</li> </ul>		✓	Personal protective equipment will be provided to workers. Regular training will also be conducted to ensure that workers are aware of the health hazards of working in excavation and construction sites.
<ul style="list-style-type: none"> <li>Dislocation or involuntary resettlement of people?</li> </ul>		✓	No displacement of communities is required in this project.
<ul style="list-style-type: none"> <li>Disproportionate impacts on the poor, women and children, indigenous peoples, or other vulnerable groups?</li> </ul>		✓	Not applicable
<ul style="list-style-type: none"> <li>Noise and dust from construction activities?</li> </ul>	✓		Anticipated during construction activities. However, impacts are temporary and short in duration. The EMP includes measures to mitigate the impacts.
<ul style="list-style-type: none"> <li>Increased road traffic due to interference of construction activities?</li> </ul>	✓		Anticipated during construction activities. However, impacts are temporary and short in duration. The EMP ensures measures are included to mitigate the impacts. Construction contractors will be required to coordinate with the local traffic police.
<ul style="list-style-type: none"> <li>Continuing soil erosion/silt runoff from construction operations?</li> </ul>		✓	Not anticipated, as topography of Dhaka is plain. However, the EMP still includes measures to mitigate the impacts. Construction contractors will be required to include channelization where required.
<ul style="list-style-type: none"> <li>Delivery of unsafe water due to poor OandM treatment processes (especially mud accumulations in filters) and inadequate chlorination due to lack of adequate monitoring of chlorine residuals in distribution systems?</li> </ul>		✓	Not anticipated
<ul style="list-style-type: none"> <li>Delivery of water to distribution system, which is corrosive due to inadequate attention to feeding of corrective chemicals?</li> </ul>		✓	Not anticipated. Water quality is being regularly monitored by DWASA.
<ul style="list-style-type: none"> <li>Accidental leakage of chlorine gas?</li> </ul>		✓	Not anticipated
<ul style="list-style-type: none"> <li>Excessive abstraction of water affecting downstream water users?</li> </ul>		✓	Not anticipated. Water quantity is sufficient and there is no additional abstraction.
<ul style="list-style-type: none"> <li>Competing uses of water?</li> </ul>		✓	Not anticipated
<ul style="list-style-type: none"> <li>Increased sewage flow due to increased water supply?</li> </ul>	✓		Sewerage system improvement will be undertaken by DWASA.
<ul style="list-style-type: none"> <li>Increased volume of sullage (wastewater from cooking and</li> </ul>		✓	Sewerage system improvement will be undertaken by CMC.

<b>Screening Questions</b>	<b>Yes</b>	<b>No</b>	<b>Remarks</b>
washing) and sludge from wastewater treatment plant?			
<ul style="list-style-type: none"> <li>Large population influx during project construction and operation that causes increased burden on social infrastructure and services (such as water supply and sanitation systems)?</li> </ul>		✓	Improved water supply management systems through capacity building and institutional development will ensure reduced burden on services and infrastructure.
<ul style="list-style-type: none"> <li>Social conflicts if workers from other regions or countries are hired?</li> </ul>		✓	Priority in employment will be given to local residents.
<ul style="list-style-type: none"> <li>Risks to community health and safety due to the transport, storage, and use and/or disposal of materials such as explosives, fuel, and other chemicals during operation and construction?</li> </ul>		✓	Not applicable. Trenching will be done manually. Construction will not involve use of explosives. For rock and concrete breaking, contractors will be required to use non-explosive blasting chemicals, silent rock cracking chemicals, and concrete breaking chemicals. These products come in powder form, and once mixed with water (being the catalyst), simply expand and crack the rock/concrete from hole to hole. Chemical material safety data sheets will be posted in conspicuous areas. The EMP ensures measures are included for the storage areas.
<ul style="list-style-type: none"> <li>Community safety risks due to both accidental and natural hazards, especially where the structural elements or components of the project are accessible to members of the affected community, or where their failure could result in injury to the community throughout project construction, operation, and decommissioning?</li> </ul>		✓	Operational area will be clearly demarcated and access will be controlled. Only workers and project concerned members will be allowed to visit the operational sites.
<b>Climate Change and Disaster Risk Questions</b> The following questions are not for environmental categorization. They are included in this checklist to help identify potential climate and disaster risks.	<b>Yes</b>	<b>No</b>	<b>Remarks</b>
<ul style="list-style-type: none"> <li>Is the project area subject to hazards such as earthquakes, floods, landslides, tropical cyclone winds, storm surges, tsunami, volcanic eruptions, and climate changes (see Appendix I)?</li> </ul>		✓	Environmental factors like lithology, regolith characteristics have very limited or no influence on the foundation, which are already found to be suitable, and the area is free from landslide problems. Any proposed facility will require compliance with government rules for seismic design.
<ul style="list-style-type: none"> <li>Could changes in temperature, precipitation, or extreme events patterns over the Project lifespan affect technical or financial sustainability (e.g., increased extreme rainfall increases flooding, damaging proposed infrastructure)?</li> </ul>		✓	
<ul style="list-style-type: none"> <li>Are there any demographic or socio-economic aspects of the Project area that are already vulnerable (e.g., high incidence of marginalized populations, rural-urban migrants, illegal settlements, ethnic minorities, women or children)?</li> </ul>		✓	Proposed project will not impact any marginalized population, rural-urban migrants, illegal settlement, etc.
<ul style="list-style-type: none"> <li>Could the Project potentially increase the climate or disaster vulnerability of the surrounding area (e.g., by paving vulnerable groundwater recharge areas, or using water from a vulnerable source that is relied upon by many user groups, or encouraging settlement in earthquake zones)?</li> </ul>		✓	

**APPENDIX 2: DETAILED COMPONENTS OF DMA 601, 605, 607 & 608 OF PACKAGE NO. ICB 2.7**

<b>Item</b>	<b>Description</b>	<b>Unit</b>	<b>Qty.</b>
4.3	INSTALLATION DMA 601		
4.3.3	Installation of Distribution pipes through open trench, pipe bursting and HDD method including installation of burried Gate Valves and Wash Out up to 200 mm dia, Data Loggers (DLs), Non Return Valves as required and approved, but excluding valves and DLs for PTWs & Interconnection Chambers for isolation of DMA (all gate valves, DLs and NRVs are of Employer's Supply)	m	18,439.5
4.3.4	Installation of Reticulation pipes through open trench and HDD method including installation of burried Gate Valves, Wash Out (all gate valves are of Employer's Supply)	m	6157.2
4.3.5	Rehabilitation of service connections of length as required including supply of saddles, Ferrule, transition coupler, gate valves, float valves, meter chamber incl. required fittings for the meter to be placed within 0.6 meter from ground level all complete (water meters are of Employer's Supply)	nos.	1551
4.3.6	Upgrading of Tube Wells (PTWs)	nos.	9
4.3.7	Construction of Gate Valve Chamber, Interconnection Chamber and Interconnection with transmission main of approved design including necessary fittings and fixtures, excavation and backfilling all complete (valves, meters and data loggers are of Employer's Supply)		
4.3.7.1	Construction of RCC Gate Valve Chamber for pipeline of 315 mm dia and above including installation of gate valves with necessary fittings, fixtures all complete as per approved design, drawing and direction of project manager	nos.	18
4.3.7.2	Construction of RCC Interconnection chamber for isolation of DMA where required including installation of Pressure Sustaining Valves, Pressure Reducing Valves, Air Release Valves, Non Return Valves, Bulk Water Meters and Data Loggers with all fittings, fixtures all complete as per approved design, drawing and direction of project manager	nos.	4
4.3.7.3	Interconnection with the existing water transmission main from 300 mm to 600 mm diameter where required including supply of Tee, Reducer with fittings, fixtures all complete as per approved design, drawing and direction of project manager	nos.	1
4.4	INSTALLATION DMA 605		According to Draft Model Design
4.4.3	Installation of Distribution pipes through open trench, pipe bursting and HDD method including installation of burried Gate Valves and Wash Out up to 200 mm dia, Data Loggers (DLs), Non Return Valves as required and approved, but excluding valves and DLs for PTWs & Interconnection Chambers for isolation of DMA (all gate valves, DLs and NRVs are of Employer's Supply)	m	46,756.0
4.4.4	Installation of Reticulation pipes through open trench and HDD method including installation of burried Gate Valves, Wash Out (all gate valves are of Employer's Supply)	m	Detailed design is not done yet
4.4.5	Rehabilitation of service connections of length as required including supply of saddles, Ferrule, transition coupler, gate valves, float valves, meter chamber incl. required fittings for the meter to be placed within 0.6 meter from ground level all complete (water meters are of Employer's Supply)	nos.	4802
4.4.6	Upgrading of Tube Wells (PTWs)	nos.	6
4.4.7	Construction of Gate Valve Chamber, Interconnection Chamber and Interconnection with transmission main of approved design including necessary fittings and fixtures, excavation and back filling all complete (valves, meters and data loggers are of Employer's	nos.	Detailed design is not done yet

	Supply)		
4.4.7.1	Construction of RCC Gate Valve Chamber for pipeline of 315 mm dia and above including installation of gate valves with necessary fittings, fixtures all complete as per approved design, drawing and direction of project manager	nos.	Detailed design is not done yet
4.4.7.2	Construction of RCC Interconnection chamber for isolation of DMA where required including installation of Pressure Sustaining Valves, Pressure Reducing Valves, Air Release Valves, Non Return Valves, Bulk Water Meters and Data Loggers with all fittings, fixtures all complete as per approved design, drawing and direction of project manager	nos.	Detailed design is not done yet
4.4.7.3	Interconnection with the existing water transmission main from 300 mm to 600 mm diameter where required including supply of Tee, Reducer with fittings, fixtures all complete as per approved design, drawing and direction of project manager	nos.	Detailed design is not done yet
4.5	INSTALLATION DMA 607		
4.5.3	Installation of Distribution pipes through open trench, pipe bursting and HDD method including installation of burried Gate Valves and Wash Out up to 200 mm dia, Data Loggers (DLs), Non Return Valves as required and approved, but excluding valves and DLs for PTWs & Interconnection Chambers for isolation of DMA (all gate valves, DLs and NRVs are of Employer's Supply)	m	12,028.0
4.5.4	Installation of Reticulation pipes through open trench and HDD method including installation of burried Gate Valves, Wash Out (all gate valves are of Employer's Supply)	m	4,328.9
4.5.5	Rehabilitation of service connections of length as required including supply of saddles, Ferrule, transition coupler, gate valves, float valves, meter chamber incl. required fittings for the meter to be placed within 0.6 meter from ground level all complete (water meters are of Employer's Supply)	nos.	1456
4.5.6	Upgrading of Tube Wells (PTWs)	nos.	3
4.5.7	Construction of Gate Valve Chamber, Interconnection Chamber and Interconnection with transmission main of approved design including necessary fittings and fixtures, excavation and back filling all complete (valves, meters and data loggers are of Employer's Supply)		
4.5.7.1	Construction of RCC Gate Valve Chamber for pipeline of 315 mm dia and above including installation of gate valves with necessary fittings, fixtures all complete as per approved design, drawing and direction of project manager	nos.	6
4.5.7.2	Construction of RCC Interconnection chamber for isolation of DMA where required including installation of Pressure Sustaining Valves, Pressure Reducing Valves, Air Release Valves, Non Return Valves, Bulk Water Meters and Data Loggers with all fittings, fixtures all complete as per approved design, drawing and direction of project manager	nos.	2
4.5.7.3	Interconnection with the existing water transmission main from 300 mm to 600 mm diameter where required including supply of Tee, Reducer with fittings, fixtures all complete as per approved design, drawing and direction of project manager	nos.	0
4.6	INSTALLATION DMA 608		
4.6.3	Installation of Distribution pipes through open trench, pipe bursting and HDD method including installation of burried Gate Valves and Wash Out up to 200 mm dia, Data Loggers (DLs), Non Return Valves as required and approved, but excluding valves and DLs for PTWs	m	24,250.0

	& Interconnection Chambers for isolation of DMA (all gate valves, DLs and NRVs are of Employer's Supply)		
4.6.4	Installation of Reticulation pipes through open trench and HDD method including installation of buried Gate Valves, Wash Out (all gate valves are of Employer's Supply)	m	Detailed design is not done yet
4.6.5	Rehabilitation of service connections of length as required including supply of saddles, Ferrule, transition coupler, gate valves, float valves, meter chamber incl. required fittings for the meter to be placed within 0.6 meter from ground level all complete (water meters are of Employer's Supply)	nos.	2421
4.6.6	Upgrading of Tube Wells (PTWs)	nos.	5
4.6.7	Construction of Gate Valve Chamber, Interconnection Chamber and Interconnection with transmission main of approved design including necessary fittings and fixtures, excavation and back filling all complete (valves, meters and data loggers are of Employer's Supply)		Detailed design is not done yet
4.6.7.1	Construction of RCC Gate Valve Chamber for pipeline of 315 mm dia and above including installation of gate valves with necessary fittings, fixtures all complete as per approved design, drawing and direction of project manager	nos.	Detailed design is not done yet
4.6.7.2	Construction of RCC Interconnection chamber for isolation of DMA where required including installation of Pressure Sustaining Valves, Pressure Reducing Valves, Air Release Valves, Non Return Valves, Bulk Water Meters and Data Loggers with all fittings, fixtures all complete as per approved design, drawing and direction of project manager	nos.	Detailed design is not done yet
4.6.7.3	Interconnection with the existing water transmission main from 300 mm to 600 mm diameter where required including supply of Tee, Reducer with fittings, fixtures all complete as per approved design, drawing and direction of project manager	nos.	Detailed design is not done yet

APPENDIX 3: RECORDS OF PROJECT INFORMATION DISCLOSURE MEETING DMA 601

A. Attendance List

Dhaka Environmentally Sustainable Water Supply Project (DESWSP) Name of Meeting: Project Information Disclosure Meeting Venue: Banosree Welfare Samity Date: 18/10/2016 Time: 6:30 PM				
Sl#	Name	Designation	Organization	Signature & Mobile NO
1.	Md. Mahamudul Islam	PD	DESWSP. DWBSA	<i>[Signature]</i>
2.	Abdul Haque	G.C	BKS	<i>[Signature]</i>
3.	Atem Jafar Ullah	ED/RFL	CMR 2-7 package	<i>[Signature]</i>
4.	Nurul Alam	V.P.	BKS	<i>[Signature]</i>
5.	Md. Khurshed Alam	VP	BKS	<i>[Signature]</i>
6.	Md. Abdul Barakat	VP	BKS	<i>[Signature]</i>
7.	Engg. Md. Motin Rahman	Road Repair	development (Maintenance Section)	<i>[Signature]</i>
8.	M. Ayub Khan			<i>[Signature]</i>
9.	Md. Jashim Rahman Khan		BKS	<i>[Signature]</i> 18.10.2016
10.	Engg. M.H. Rashid		BKS	<i>[Signature]</i>
11.	Md. Asraf Hossain Mondol		BKS	<i>[Signature]</i>
12.	Md. Hashim Rahman		RFL (Site Manager)	<i>[Signature]</i>
13.	Rahmanullah		B.K.S	<i>[Signature]</i> 18/10/2016
14.	Md. Anamul Hossain Babu		B.K.S	<i>[Signature]</i> 18/10/16
15.	Md. Barakat Ali		B.K.S	<i>[Signature]</i> 18-10-2016
16.	ABM NAZMUL ALAM		BKS	<i>[Signature]</i> 18-10-2016
17.	Delashis Bhattacharya		BKS	<i>[Signature]</i> 18.10.16
18.	Md. Shuhidul Islam		BKS	<i>[Signature]</i> 18/10/16
19.	Abdul Maleque Senik		BKS	<i>[Signature]</i>
20.	Md. Saikat Hossain		BKS	<i>[Signature]</i> 18/10/16
21.	Md. Atikul Islam		APE/RFL	<i>[Signature]</i> 18/10/16
22.	Md. Mostafizul Alam	Team leader	Samatar	<i>[Signature]</i> 01743947932
23.	Mr. He Jun Rahum	social	environmental expert MSE	<i>[Signature]</i> 01712532003
24.	A.N.M. Shamsul Hossain	Water Supply	M.S.C. Kalesh Engineers	<i>[Signature]</i> 18/10/2016
25.	Md. Abdul Bari		MSE	<i>[Signature]</i> 18.10.16
26.	Kazi Habib Ullah	Partner	RFL	<i>[Signature]</i> 18/10/16
27.	Md. Abul Kalam	President	B.K.S	<i>[Signature]</i> 18/10/16

**B. Photos of Public Consultation & Project Information Disclosure**

 A long conference room with a long table where several people are seated, engaged in a meeting. A man in a patterned shirt and white cap is in the foreground, looking towards the others.	 A group of people seated around a long table in a meeting room, with a man in a white cap and patterned shirt speaking to the group.	 A public consultation meeting with a man standing at the front of a room, addressing a group of people seated at tables.
<p>Project Information Disclosure Meeting on 18.10.16</p>	<p>PD, DWASA Briefing on Project Background</p>	<p>Public Consultation Meeting on 17.10.2016</p>
 A woman in a pink hijab and a man in a grey shirt sitting at a desk with a laptop, talking to a woman in a purple sari.	 A man in a blue shirt sitting on the floor, looking at documents, with a shopping cart and various items around him.	 A group of people, including women in hijabs and men, sitting at a table during a public consultation meeting.
<p>Institution Visit at DMA 601 on 16.10.2016</p>	<p>Vendor Selection at DMA 601 on 16.10.2016</p>	<p>Audience of Public Consultation Meeting on 17.10.16</p>

## APPENDIX 4: SAMPLE GRIEVANCE REDRESS FORM

(To be available in Bangla and English)

The \_\_\_\_\_ Project welcomes complaints, suggestions, queries, and comments regarding project implementation. We encourage persons with grievance to provide their name and contact information to enable us to get in touch with you for clarification and feedback.

Should you choose to include your personal details but want that information to remain confidential, please inform us by writing/typing \*(CONFIDENTIAL)\* above your name. Thank you.

<b>Date</b>	<b>Place of Registration</b>			
<b>Contact Information/Personal Details</b>				
<b>Name</b>		<b>Gender</b>	* Male * Female	<b>Age</b>
<b>Home Address</b>				
<b>Place</b>				
<b>Phone no.</b>				
<b>E-mail</b>				
<b>Complaint/Suggestion/Comment/Question</b> Please provide the details (who, what, where, and how) of your grievance below:				
If included as attachment/note/letter, please tick here:				
<b>How do you want us to reach you for feedback or update on your comment/grievance?</b>				

### FOR OFFICIAL USE ONLY

<b>Registered by:</b> (Name of Official registering grievance)	
<b>Mode of communication:</b> Note/Letter E-mail Verbal/Telephonic	
<b>Reviewed by:</b> (Names/Positions of Officials Reviewing Grievance)	
<b>Action Taken:</b>	
<b>Whether Action Taken Disclosed:</b>	Yes No
<b>Means of Disclosure:</b>	

## APPENDIX 5: ENVIRONMENTAL REPORTING

### A. SUGGESTED OUTLINE FOR THE ENVIRONMENTAL MONITORING REPORT

#### I. Introduction

- Overall project description and objectives
- Description of subprojects
- Environmental category of the sub-projects
- Details of site personnel and/or consultants responsible for environmental monitoring
- Overall project and sub-project progress and status

No.	Sub-Project Name	Status of Sub-Project				List of Works	Progress of Works
		Design	Pre-Construction	Construction	Operational Phase		
		<input type="checkbox"/>	<input type="checkbox"/>	<input type="checkbox"/>	<input type="checkbox"/>		
		<input type="checkbox"/>	<input type="checkbox"/>	<input type="checkbox"/>	<input type="checkbox"/>		
		<input type="checkbox"/>	<input type="checkbox"/>	<input type="checkbox"/>	<input type="checkbox"/>		

#### II. Compliance Status

##### 1. Compliance Status with National/State/Local Statutory Environmental Requirements

No.	Sub-Project Name	Statutory Environmental Requirements	Status of Compliance	Action Required

##### 2. Compliance Status with Environmental Loan Covenants

No. (List schedule and paragraph number of Loan Agreement)	Covenant	Status of Compliance	Action Required

##### 3. Compliance status with the environmental management and monitoring plan

- Provide the monitoring results as per the parameters outlined in the EMP. Append supporting documents where applicable, including Environmental Site Inspection Reports (refer to Appendix 7 of this IEE).
- Provide summary of the Environmental Site Inspection Report (findings, corrective action plan, and recommendations)
- Provide summary of the complaint/s received, nature of complaints, and actions taken management system
- Provide summary of information disclosure, consultations, FGDs, and other awareness building activities
- Provide summary of environment-related capacity building activities.

##### Summary Monitoring Table

Impacts (List from IEE)	Mitigation Measures (List from IEE)	Parameters Monitored (As a minimum those identified in the IEE should be monitored)	Method of Monitoring	Location of Monitoring	Date of Monitoring Conducted	Name of Person Who Conducted the Monitoring
Design Phase						

Impacts (List from IEE)	Mitigation Measures (List from IEE)	Parameters Monitored (As a minimum those identified in the IEE should be monitored)	Method of Monitoring	Location of Monitoring	Date of Monitoring Conducted	Name of Person Who Conducted the Monitoring
Pre-Construction Phase						
Construction Phase						
Operational Phase						

## Overall Compliance with EMP

No.	Sub-Project Name	EMP/ CEMP Part of Contract Documents (Y/N)	CEMP/ EMP Being Implemented (Y/N)	Status of Implementation (Excellent/ Satisfactory/ Partially Satisfactory/ Below Satisfactory)	Action Proposed and Additional Measures Required

4. Approach and methodology for environmental monitoring of the project
- Brief description on the approach and methodology used for environmental monitoring of each sub-project
  - Brief discussion on the basis for monitoring
  - Indicate type and location of environmental parameters to be monitored
  - Indicate the method of monitoring and equipment to be used
  - Provide monitoring results and an analysis of results in relation to baseline data and statutory requirements
  - As a minimum the results should be presented as per the tables below.

## Air Quality Results

Site No.	Date of Testing	Site Location	Parameters (Government Standards)		
			PM10 µg/m3	SO2 µg/m3	NO2 µg/m3

Site No.	Date of Testing	Site Location	Parameters (Monitoring Results)		
			PM10 µg/m3	SO2 µg/m3	NO2 µg/m3

Water Quality Results

Site No.	Date of Sampling	Site Location	Parameters (Government Standards)					
			pH	Conductivity $\mu\text{S/cm}$	BOD mg/L	TSS mg/L	TN mg/L	TP mg/L

Site No.	Date of Sampling	Site Location	Parameters (Monitoring Results)					
			pH	Conductivity $\mu\text{S/cm}$	BOD mg/L	TSS mg/L	TN mg/L	TP mg/L

Noise Quality Results

Site No.	Date of Testing	Site Location	LAeq (dBA) (Government Standard)	
			Day Time	Night Time

Site No.	Date of Testing	Site Location	LAeq (dBA) (Monitoring Results)	
			Day Time	Night Time

5. Summary of key issues and remedial actions
  - Summary of follow up time-bound actions to be taken within a set timeframe.
  
6. Appendixes
  - Photos
  - Summary of consultations
  - Copies of environmental clearances and permits

**B. SAMPLE ENVIRONMENTAL SITE INSPECTION REPORT****Checklist for Environmental Inspection at Work Sites**

Date:

DMA No :	Location :
Weather Condition :	Road Name/No. :
Work Status :	

SI. No.	Checking Issues	Y	N	Remarks/Notes
1	<b>Site Office</b>			
	• Is site office established?			
	• Health and Safety Officer (HSO)			
	• Site Environmental Plan (SEP)			
	• First aid box with first aiding agents in site office			
	• Trained up First Aid provider?			
	• Fire extinguisher/protective arrangements			
	• Emergency contacts in case of any incident			
	• Number of households needed temporary water supply			
	• Availability of Display board showing SEP in the site office			
	• Pictures of before and after completion of work on board			
	• Incident register book			
	• complain/ visitor's comment book			
2	<b>Labor and Equipment Shed</b>			
	Is any shed established?			
	• Hygiene, Sanitation etc. facilities			
	• Bin for collecting garbage and food waste			
	• Wastewater disposal system			
	• Special facilities for female labor (dress-up, breast feeding, etc.)			
	• Measures against mosquito, insects, etc. problems			
4	<b>Roads safety and Traffic Management</b>			
	• Public consultation/FGD conducted?			
	• Safety signboards/barriers/barricades at starting of the roads where installation work is in progress			

Sl. No.	Checking Issues	Y	N	Remarks/Notes
	<ul style="list-style-type: none"> <li>Traffic management scheme</li> </ul>			
	<ul style="list-style-type: none"> <li>Road diversion barrier and signal</li> </ul>			
	<ul style="list-style-type: none"> <li>Warning stand with tape when cutting pit for house connection and during OT, PB, HDD</li> </ul>			
	<ul style="list-style-type: none"> <li>Plane sheet covering over house connection pit with warning stand and tape</li> </ul>			
<b>5</b>	<b>Occupational Health and Safety</b>			
	<ul style="list-style-type: none"> <li>Personal Protective Equipment (PPEs)</li> </ul>			
	<ul style="list-style-type: none"> <li>Incident records and steps taken</li> </ul>			
	<ul style="list-style-type: none"> <li>Training on OHS, PPE and others before starting installation in new DMA</li> </ul>			
	<ul style="list-style-type: none"> <li>Awareness raising program for practicing PPE</li> </ul>			
<b>6</b>	<b>Environmental Quality</b>			
	<ul style="list-style-type: none"> <li>Air quality monitoring</li> </ul>			
	<ul style="list-style-type: none"> <li>Noise quality monitoring</li> </ul>			
	<ul style="list-style-type: none"> <li>Dust and litter controlling activities</li> </ul>			
	<ul style="list-style-type: none"> <li>Generated wastewater management system</li> </ul>			
	<ul style="list-style-type: none"> <li>AC Pipes handling in field</li> </ul>			
	<ul style="list-style-type: none"> <li>Management of excavated soil</li> </ul>			
	<ul style="list-style-type: none"> <li>Any Utility service damage?</li> </ul>			
	<ul style="list-style-type: none"> <li>Measures taken to destructed trees and vegetation</li> </ul>			
	<ul style="list-style-type: none"> <li>Any private property damage?</li> </ul>			
	<ul style="list-style-type: none"> <li>Is generated construction waste/debris removed?</li> </ul>			
	<ul style="list-style-type: none"> <li>Pipe joint condition</li> </ul>			
	<ul style="list-style-type: none"> <li>Water reuse</li> </ul>			

Collected by

Reviewed by

Signature

Signature

.....

.....

Name :

Name :

Position: Environmental Inspector

Position: Environmental Management Expert

**APPENDIX 6: SITE ENVIRONMENTAL PLAN OF DMA 601, 605, 607 & 608**

### A. Site Environmental Plan of DMA-601

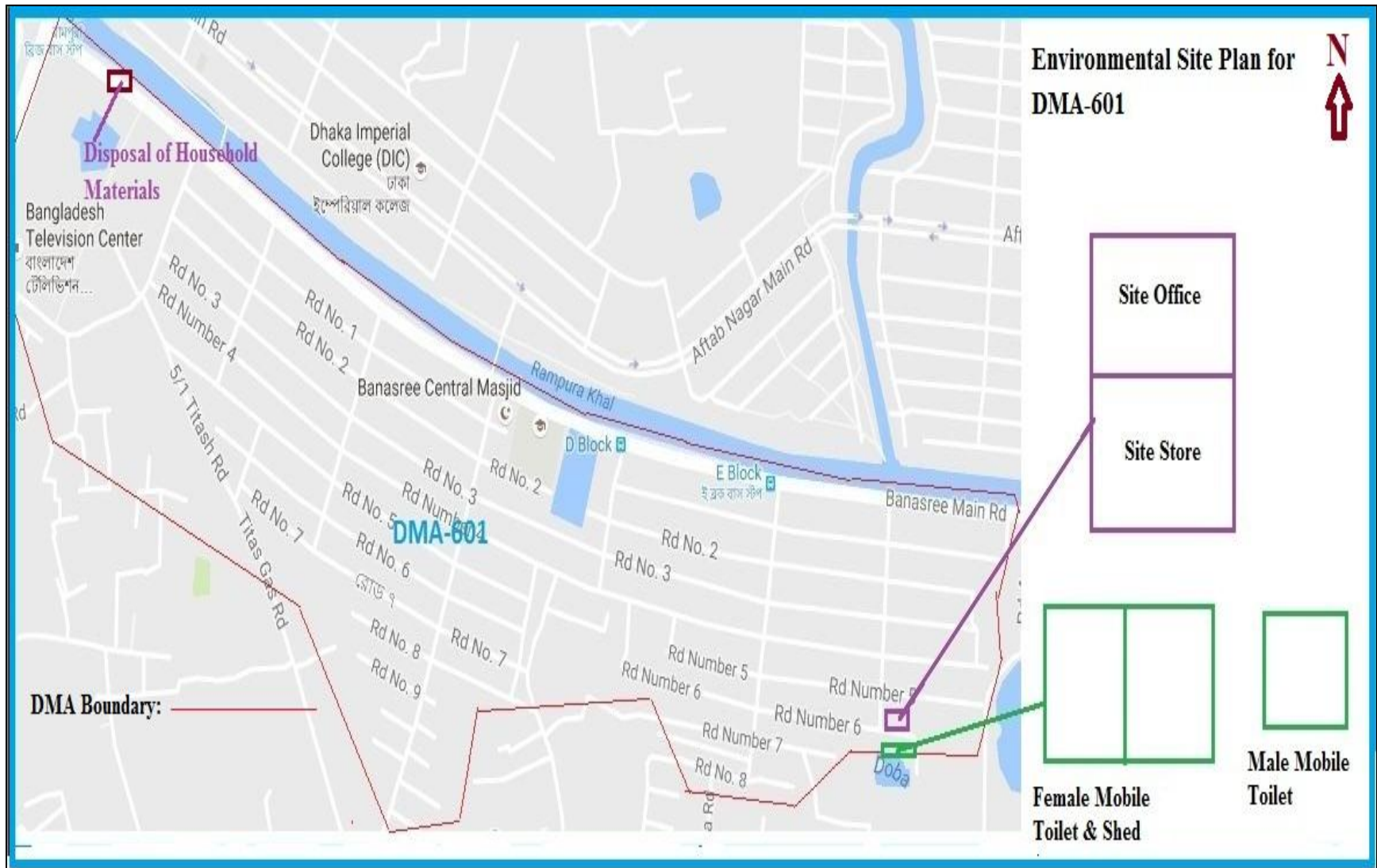

Source: EMP of DMA 601, 605, 607 & 608

**B. Site Environmental Plan of DMA-605**

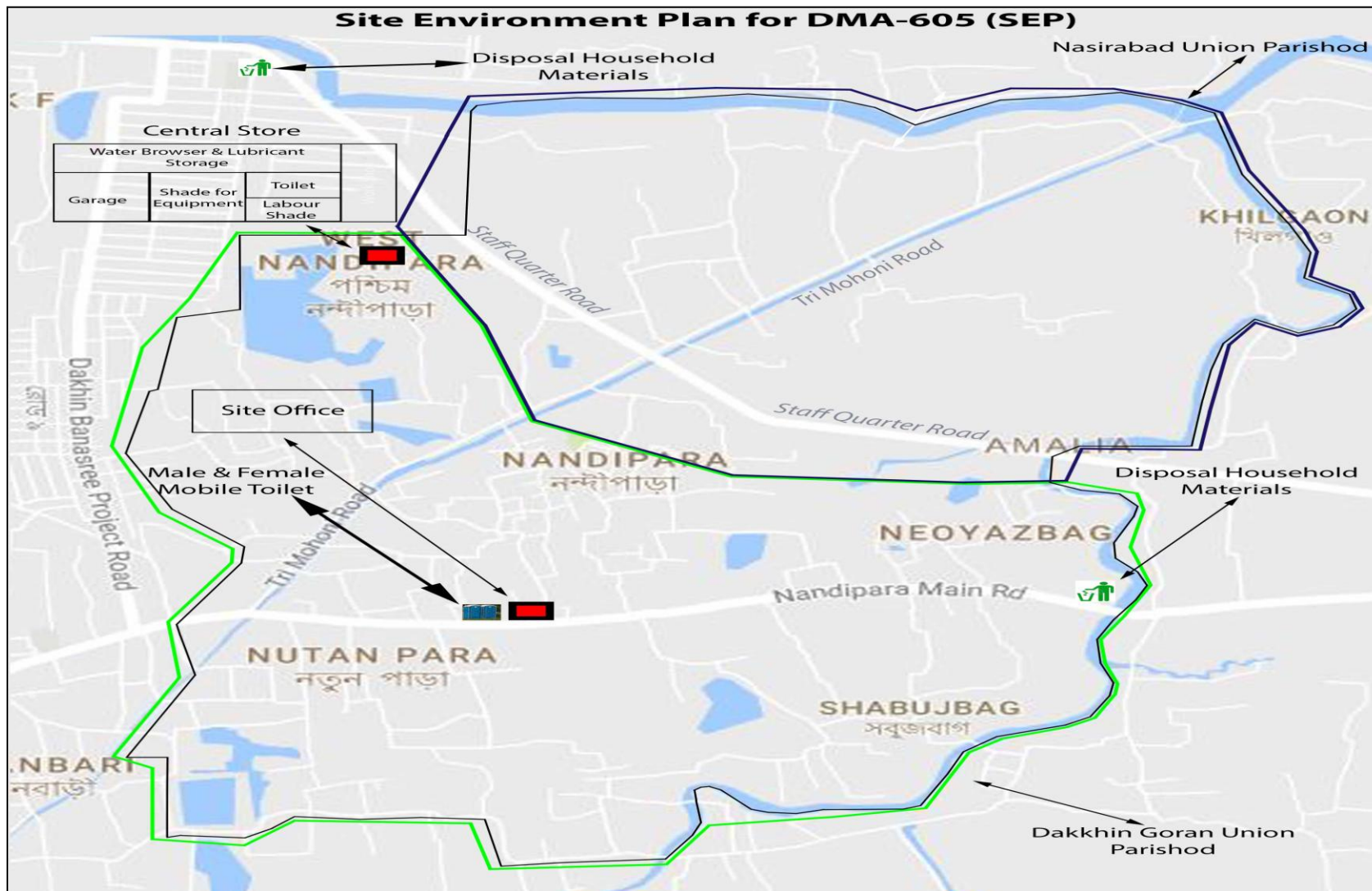

Source: EMP of DMA 601, 605, 607 & 608



**D. Site Environmental Plan of DMA-608**

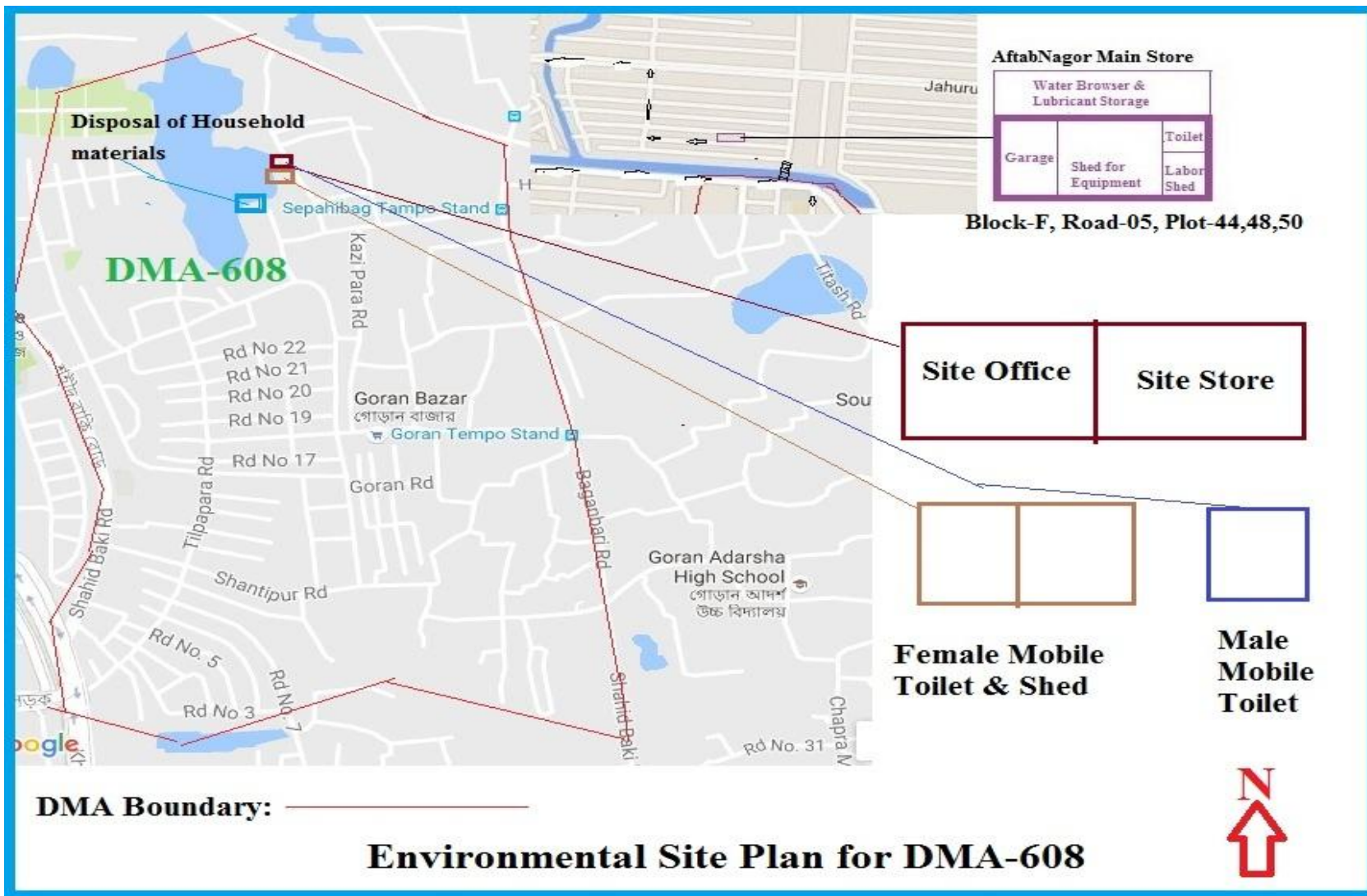

Source: EMP of DMA 601, 605, 607 & 608

**APPENDIX 7: IMPLIMENTATION PLAN OF PACKAGE ICB 02.7**

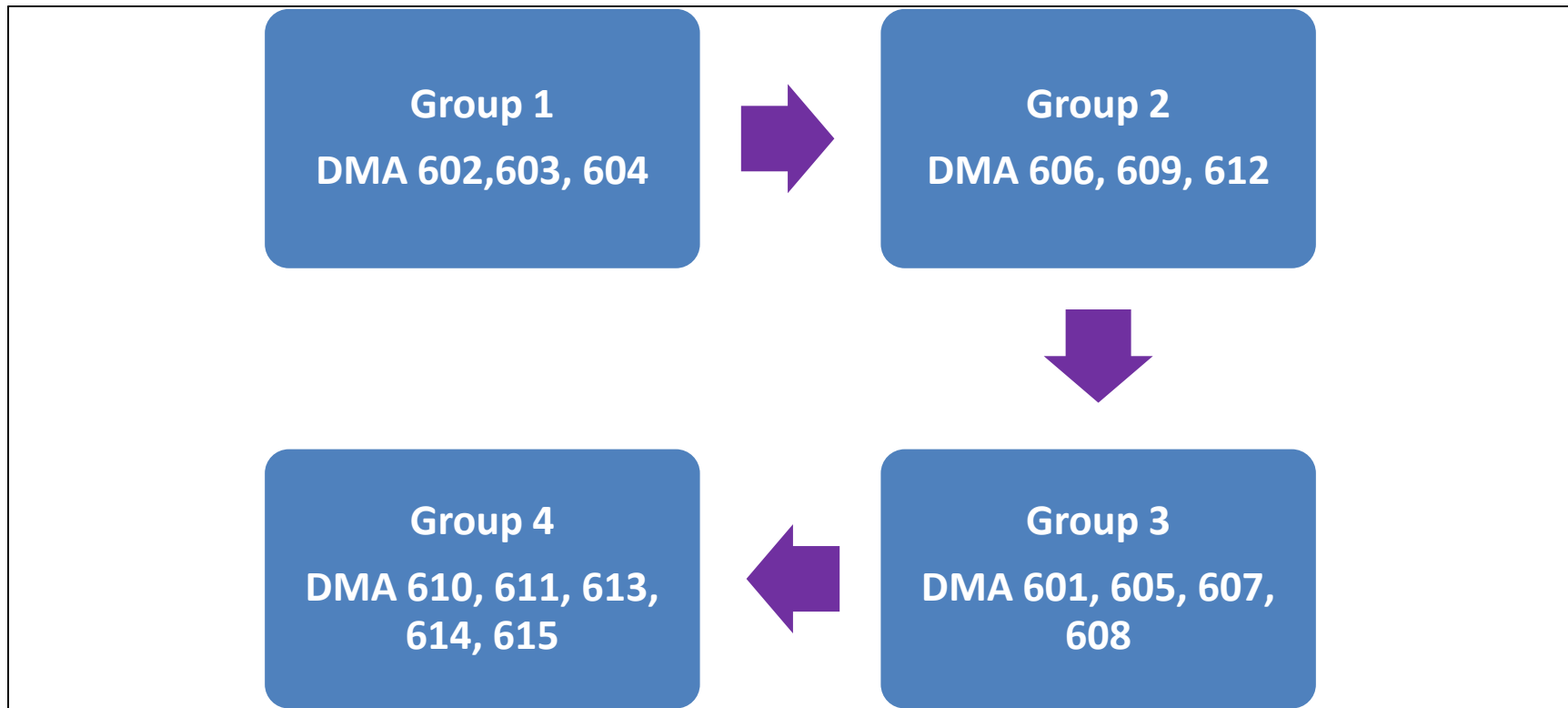

Source: EMP of DMA 601, 605, 607 & 608

**APPENDIX 8: WORKSHOP ON EMP IMPLEMENTATION OF ICB 02.7**

**Workshop Participants**

The workshop welcomed 52 participants from PMU, PCU, MSC, Contractors & Sub-contractors, and NGO. The list of participants and two photos are shown below.

Capacity Building Workshop on EMP Implementation: Date:09-11-2016, NGO SHAMAHAR Office, Banasree, Rampura, Dhaka-1219					
SL No	Name	Designation	Organization	Mobile number	Signature
1.	Md. Mahmudul Islam	PD, DESWSP	DWASA	01922198790	
2.	Kosiduddin Khan	TL	MSE	01720152991	
3.	Abul Jafarullah	CM DPL-FSL		01711546992	
4.	Baharul Islam	DPD	DWASA	01741584893	
5.	ATM Mujibur Rahman	E.E.	DWASA	01711403032	
6.	M. M. Islam	SNSE, PMU	DWASA	01730041534	
7.	Md. Abdul Bari	2ME, MSE	MBC	91781165811	
8.	Mir Kashem Mazumder	RPL-FSL	F.S.L	01833226627	
9.	Md. Shafiqur Rahman	SE+DPD	DWASA	01676735981	
10.	MO ALAMUR	Assistant Engr	DWASA	01712781366	
11.	Zunayed Abu Yousif	SDE, PMU	DWASA	01840101622	
12.	Md. Saichur Rahman	Safeguard Officer (Envir)	DESWSP DWASA	0175142604	
13.	Mustamizul Islam	SAE	DESWSP DWASA	01913448072	
14.	MD ALI IMAM	ARE	MSC	0198868047	
15.	Md. Sakhaat Hossain	ARE	MSC	01715023022	
16.	Atsana Afreen	SAE	DESWSP DWASA	01741281058	
17.	Mst. Hena Malika	AE	DESWSP DWASA	01720900051	
18.	Tofazzel Hossain	Safeguard officer (S&E)	DESWSP DWASA	01745-921948	
19.	Md. Mashur Rahman	Site Manager	RFL	01924601806	
20.	Md. Nasser Hossain	A-PE ICB-02-7	R.F.L	01924602327	
21.	Md. Azmatul Rahim Khan	SARE	M.S.C	01711-979087	
22.	Md. Habibul Rahman	SARE	pmu,	01816600050	
23.	Sheikh Md. Ruhul Kabir	SARE	MSC	01817546081	
24.	Md. Khondokar	SARE		0171282632	
25.	M. M. Islam	SARE		01796388952	
26.	Md. Sirajul	SARE		01730820516	
27.	Md. Sirajul	SARE		01687251675	
28.	MD. Abdul Alim	SE	RFL	01924602319	
29.	Md. Aleul Hossain	LT	R.F.L	01924602160	
30.	Abu Sofiyon	APE	RFL	01924601888	
31.	Md. Mahdi Hossain	-	R.F.L	01924601623	
32.	MD. RUBAL HOSSAIN	AE	FSL	01771349773	
33.	Sakibuzzaman	SAE, PMU	DWASA	01979110099	
34.	Md. Yousuf	SARE (M.S.C)	M.S.C.	01782751565	
35.	Sardar Mozammel Hossain	SARE-MSC	MSC	01719-884601	
36.	Md. Enamul Haq	SAE (PMU)	DWASA DESWSP	01998632834	
37.	Md. Tajjinal Islam	A.S.E.	F.S.L	01917339123	
38.	MD. TOZAMMEL HAQ	SAE (PLU)	MODS Zom No-6	01717-074798	

SL No	Name	Designation	Organization	Mobile number	Signature
39.	Md. Towhidul Islam	SAG	PMU. DWASA.	01987624921	<i>[Signature]</i>
40.	Md. Atikol Islam	APE	RPL	01554739879	<i>[Signature]</i>
41.	Md. Gopal Hossain Mollah	SAB	PMU DEWSP	01716182826	<i>[Signature]</i>
42.	Kazi Zahid Ullah	AP	RCL	01817035568	<i>[Signature]</i>
43.	Md. Shahjahan Ali	SM	RCL	01924603172	<i>[Signature]</i>
44.	Md. Ashraf Ali	SAE DWASA	DWASA	01920-725953	<i>[Signature]</i>
45.	Md. Mokiuddin	SAE, PCU	ZONE-6	01969250821	<i>[Signature]</i>
46.	Md. Mostafizur Rahman	Team Leader	SAHAMAR	01743947936	<i>[Signature]</i>
47.	Md. Arifur Rahman Muhammad	SARE	MSE	01719-725767	<i>[Signature]</i>
48.	Md. Nurul Islam	Environmental Inspector	MSC	01717088893	<i>[Signature]</i>
49.	A. R. M. Nurul Islam	Asstt. Resident Engineer	MSC	01741223540	<i>[Signature]</i>
50.	A. K. M. Shafiqul Kabir	W/S Eng	MBE	01552373779	<i>[Signature]</i>
51.	Shamrajit Kumar Sarkar	EME	MSC	01736-19819	<i>[Signature]</i>
52.	Md. Rafiqur Rahman	Office Assistant	MSC	01757366162	<i>[Signature]</i>
53.					
54.					



**APPENDIX 9: ASBESTOS CEMENT PIPE HANDLING PROTOCOL**

## ASBESTOS CEMENT (AC) PIPE HANDLING PROTOCOL



*Prepared by*

Management and Supervision Consultants for ICB 02.7  
Dhaka Environmentally Sustainable Water Supply Project

November 2016

## **Acknowledgement**

Given the dangerous nature of Asbestos Cement (AC) Pipe/ materials, MSC has developed this protocol to be applied in any instance that AC pipes are found during project implementation of ICB 02.7 to ensure that appropriate action is taken. This protocol is made based on the approach recommended by the Health and Safety Executive (UK), Health and Safety Authority (Dublin) and United States Environmental Protection Agency (USEPA).

## TABLE OF CONTENTS

<b>1. ASBESTOS CEMENT (AC) .....</b>	<b>87</b>
<b>2. DANGEROUS NATURE OF ASBESTOS CEMENT (AC).....</b>	<b>87</b>
<b>3. AC PIPE IN MODS ZONE 6.....</b>	<b>88</b>
<b>4. MANAGING EXISTING ASBESTOS CEMENT (AC) PIPE .....</b>	<b>88</b>
<b>5. PROCEDURE FOR WORKING SAFELY WITH ASBESTOS CEMENT (AC) PIPE.....</b>	<b>88</b>
<i>A. Planning and Preparation</i>	88
<i>B. Training of Employees</i>	88
<i>C. Area Segregation</i>	89
<i>D. Personal Protective Equipment (PPE) for AC Pipe Removal</i>	89
<i>E. Equipments and Methods to be Used during AC Pipe Handling</i>	90
<b>6. AC PIPE REMOVAL AND DISPOSAL .....</b>	<b>93</b>
<b>7. MARKING OF AC PIPE ABOVE GROUND.....</b>	<b>93</b>

## 1. ASBESTOS CEMENT (AC)

Asbestos cement is predominantly a mixture of cement and asbestos fibers which in a dry state has a density greater than 1 tonne per cubic metre (1000 kg/m<sup>3</sup>). It is a light grey, hard material which generally contains approximately 10% asbestos fiber, but can occasionally contain more than 10% fiber, bound in a matrix of Portland cement or autoclaved calcium silicate. It is not friable: it cannot be crushed in the hand. As the fibers are tightly bound in the cement matrix they will only be released if the material is subject to significant disturbance, such as drilling, sawing, sanding etc. It should be noted that while this material is not friable, asbestos cement can be relatively brittle and so can be broken quite easily, e.g. if dropped from a height, driven over by vehicles, or struck with tools or implements.

There are two major groups of asbestos cement products. The first comprises corrugated or profiled and flat sheets, slates, rainwater goods (gutters, downpipes and troughs), flue pipes and bends and, less commonly, decking tiles, cisterns and sumps. The second group consists mainly of asbestos cement pressure pipes for the transport of drinking water, while thinner walled asbestos cement pipes have also been used for sewage and drainage. The majority of asbestos cement products contain only chrysotile asbestos fibers but some older products may contain the more hazardous crocidolite or amosite asbestos fibres.

## 2. DANGEROUS NATURE OF ASBESTOS CEMENT (AC)

Breathing in asbestos fibers can lead to asbestos-related lung diseases, mainly cancer, which kill more people than any other single work-related illness. The diseases can take from 15 to 60 years to develop – so you and your employees will not be immediately aware of a change in someone's health after breathing in asbestos fibers. The body gets rid of any asbestos fibers taken in with food and water naturally. Asbestos fibers cannot be absorbed through the skin. The danger, therefore, from exposure to asbestos fibers arises when asbestos fibers become airborne. They form a very fine dust which is often invisible. It is important to remember that people who smoke and are exposed to asbestos fibers are at greater risk of developing lung cancer than those who do not smoke.

In summary, the primary route of concern, i.e. the route whereby asbestos fibers can get into the body and cause harm or injury, is via the inhalatory route – the action of breathing. Other potential routes of entry into the body are not a problem because the body naturally gets rid of any asbestos fibres taken in with food and water (i.e. ingestion). Also asbestos fibers cannot be absorbed through the skin. However, asbestos fibers which are airborne can enter the body when contaminated air is inhaled and can lead to the development of one of three fatal diseases:

Asbestosis – which is a scarring of the lungs

Lung cancer

Mesothelioma – which is a cancer of the lining around the lungs and stomach.

While the body's natural defense mechanisms can get rid of the larger fibers, microscopic fibers can pass into the lungs where they can cause asbestos-related diseases. Because such fibers can remain in the lungs for a long time, small but repeated exposures to materials containing asbestos can lead to the development of these diseases. This is why it is important to prevent or control exposure on every single job involving asbestos.

### **3. AC PIPE IN MODS ZONE 6**

There are only a small number of AC pipes in the existing water supply system (around 20 km). These pipes are all in the old part of the city and their location is well known and marked on maps prepared by DWASA. The design of the project involves the replacement of these pipes and this can be done without removing or disturbing them, so all AC pipes will be left in situ.

Existing AC pipes, where intact, shall be left in-situ and not disturbed. Where the AC pipe is damaged and where there is a risk of asbestos particles becoming airborne, the contractor shall follow all necessary procedures, guidelines and laws as laid out locally or by this protocol to contain and remove hazardous material.

### **4. MANAGING EXISTING ASBESTOS CEMENT (AC) PIPE**

Once an asbestos survey has been carried out, you should know, as far as is reasonably practicable, the location, type and condition of the asbestos cement. Some may be damaged, have deteriorated or degenerated with time, or be liable to be damaged as a result of its location, some may be in good condition, and some situated in areas due for maintenance, refurbishment or demolition. Based on this information, you need to make a decision on what remedial action is required and on how to manage the asbestos cement, i.e. can it be left in place or should it be removed.

### **5. PROCEDURE FOR WORKING SAFELY WITH ASBESTOS CEMENT (AC) PIPE**

#### **A. Planning and Preparation**

It is important to remember that a higher risk is caused by breathing more fibers, because the concentration is higher, or when the exposure is over a longer period, or if the work is not planned and controlled adequately in order to prevent or reduce the potential for exposure, i.e. not performed in a safe manner. The following general principles should be followed when planning the work (these points are discussed in more detail in subsequent Sections):

- Where reasonably practicable, keep asbestos cement damp when working on it, i.e. as a method of dust suppression
- Where reasonably practicable, avoid using power and pneumatic tools
- Use cleaning methods which minimise dust disturbance
- Make sure workers have adequate information on the hazards and risks associated with working with asbestos cement, and are properly trained in the correct working practices and use of control measures.

#### **B. Training of Employees**

The Contractor must arrange a training program for all personnel (including manual laborers) to enable them to understand the dangers of AC pipes and to be able to recognize them in situ. The training should include the following issues.

- The health hazards of asbestos, including the added danger of smoking and working with asbestos
- Work methods and equipment
- Correct choice, use and maintenance of personal protective equipment (PPE)
- Decontamination procedures
- Maintenance of control measures
- Emergency procedures
- Waste disposal

### C. Area Segregation

You will need to segregate the work area to prevent the spread of asbestos dust and prevent the exposure of people not involved in the work. In most cases it is sufficient to mark out the work area with signs to prevent non-asbestos workers approaching. However, if the work is likely to result in significant disturbance of the asbestos cement, you need to consider erecting a physical barrier for segregation purposes. The extent of the barrier will depend on the outcome of the risk assessment carried out before the work starts.

A physical barrier should prevent the spread of debris and airborne fibers i.e. contain any dust which may be generated during the work activity, and so also assist in cleaning up the 'contaminated area' which should be within the segregated zone.

Whatever means of segregation are used, there is a need to post asbestos warning notices. Where the limit value is liable to be exceeded, the notices must clearly state that the area is a 'respirator zone' and Respiratory Protective Equipment (RPE) must be worn. If the action level is liable to be exceeded, the area should be designated as an 'asbestos area'. Employees not engaged in the work should not be permitted into either of these designated areas.

### D. Personal Protective Equipment (PPE) for AC Pipe Removal

**i) Disposable overalls fitted with a hood**



**ii) Boots without laces (laced boots are hard to decontaminate)**



**iii) Respiratory protective equipment (RPE)**



**E. Equipments and Methods to be Used during AC Pipe Handling**

The following equipments and methods are recommended for while working with AC pipes.

**i) Snap cutters**

Snap cutters (“squeeze-and-pop” equipment) operate by means of cutting wheels mounted in a chain wrapper around the pipe barrel. Hydraulic pressure, applied by means of a remote, pneumatically, or manually operated pump, squeezes the cutting wheels into the pipe wall until the cut is made.

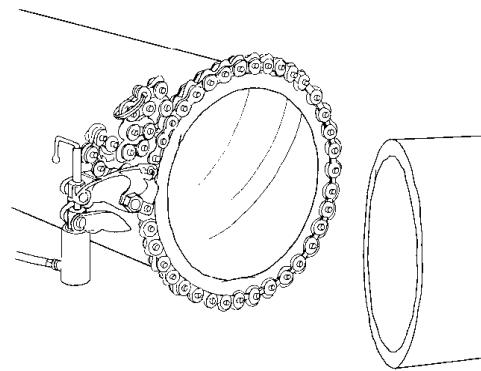

**ii) Carbide-tipped blade cutters**

Blade cutters are frame adjustable to the circumference of the pipe and have a number of self-tracking rollers that align one or more carbide-tipped cutting blades. Because of the relatively low mechanical input and clean cutting action, hand operated blade cutters do not produce significant amounts of airborne asbestos dust.

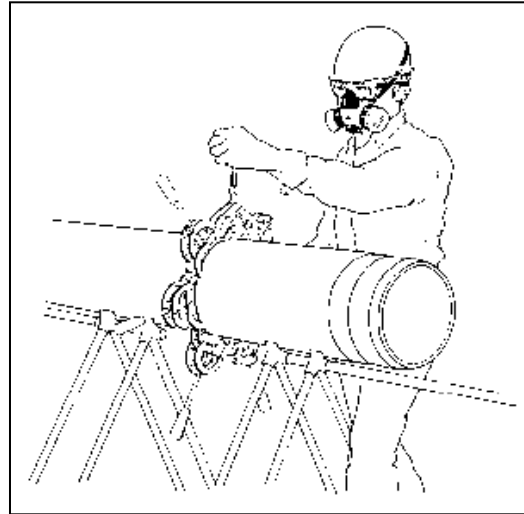
**iii) Manual field lathes**

Manual field lathes are designed to end-trim and re-machine rough pipe barrels to factory-machined end profiles. The lathe consists of an adjustable, self-aligning arbor inserted into the pipe bore (which acts as a mandrel upon which the turning handle operates), a screw-fed turning frame, carbide machining blades, and manual (hand or ratchet) turning handles.

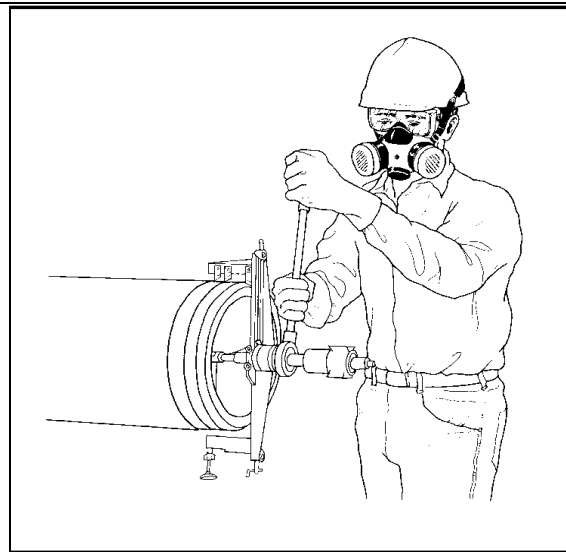
**iv) Wet tapping AC pressure pipe**

Pressure or "wet" tapping for service connections is performed in the trench while the pipe is under pressure. The equipment (manual driven) is affixed to the pipe by means of a chain yoke. A combination boring-and-inserting bar drills and taps the pipe wall and inserts a corporation stop or pipe plug. The pressure chamber, which protects against water leakage, also catches the asbestos-cement chips, so this is essentially a dust-free operation.

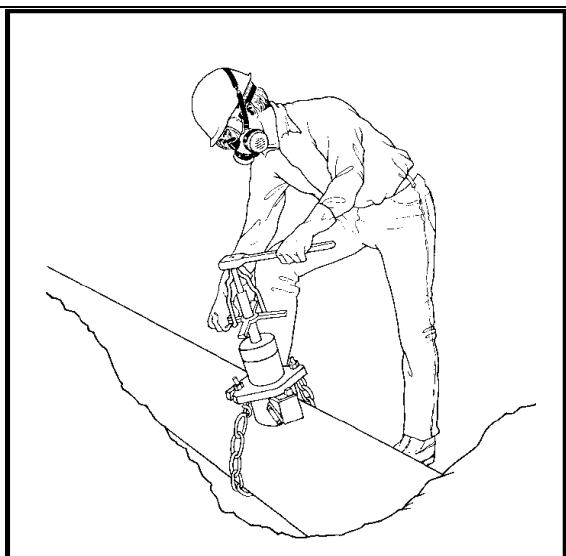

**v) Dry tapping ACD pressure pipe**

Non-pressure or “dry” tapping for service connections may be performed in or out of the trench. The equipment is affixed to the pipe by means of a chain yoke. Separate drills and taps or a combination tool is used to drill and tap the pipe wall. Corporation stops or other connections may then be affixed to the pipe.

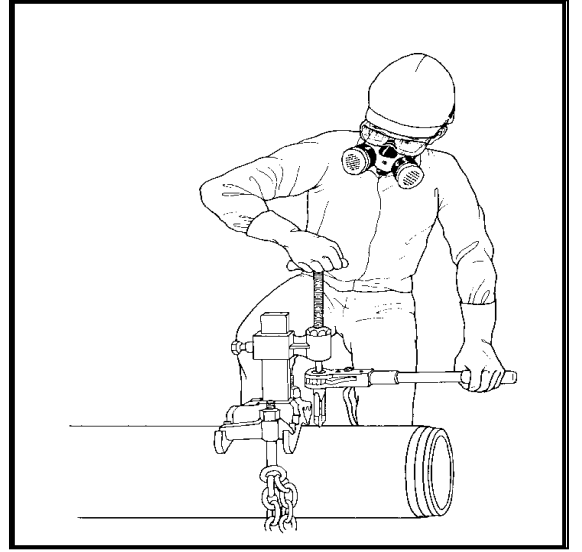
**vi) Manual rasp**

Short lengths of AC pipe, machined-end exclusively (MEE) and machined overall (MOA), can be cut to make closures and repairs and to locate fittings exactly. Field-cut ends may be re-beveled with a coarse wood rasp to form a taper approximating the profile of the factory-beveled end.

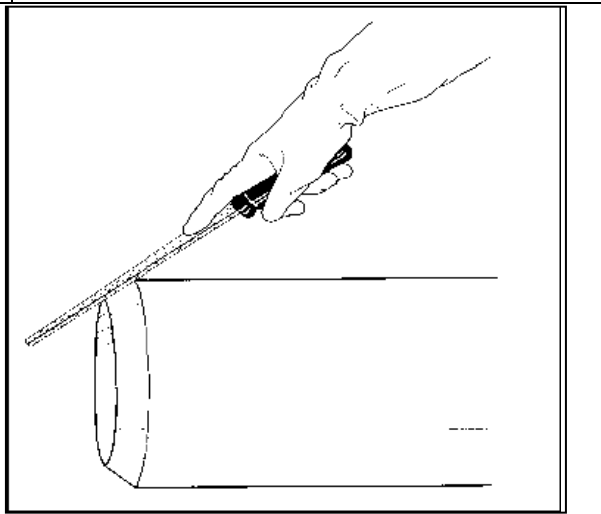
**vii) Chisel and rasp**

Holes may be cut into AC pipe with a hammer and chisel. The edge of a plumber's wood chisel is used to cut completely around the hole outline, about ¼ in. (7 mm) from the prescribed line. The operation is repeated and the cut deepened until through. The edges of the hole are then dressed with a coarse wood rasp.

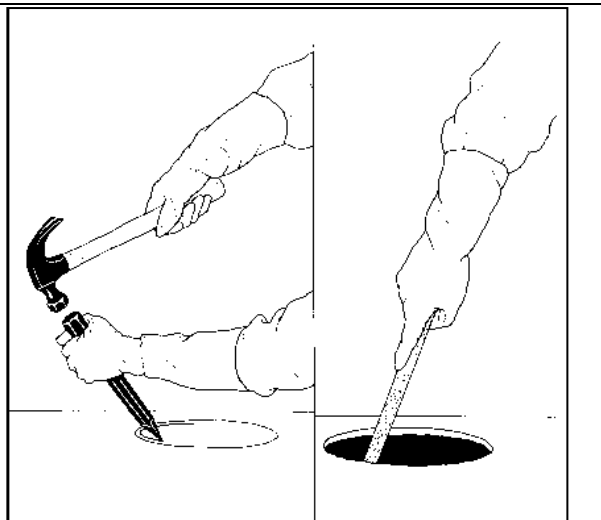

**viii) Hammer and chisel**

Replacement of damaged pipe may necessitate excavation, exposure and removal. AC coupling removal may be accomplished by gradually splitting the coupling lengthwise using a chisel and hammer. After the top of the coupling has been split, a crowbar or similar tool is used as a lever to split the bottom of the coupling.

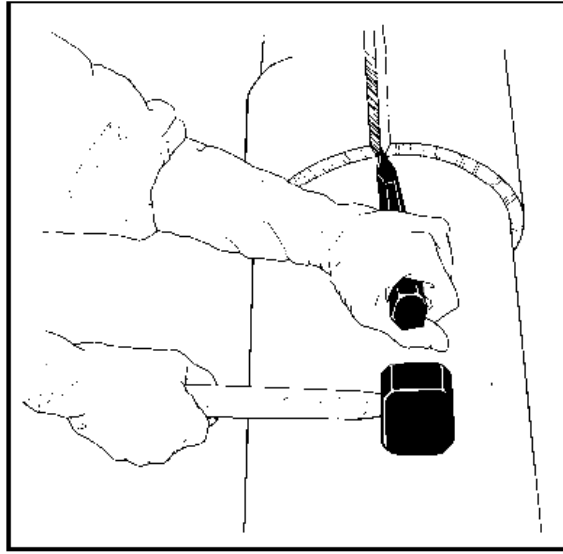
**6. AC PIPE REMOVAL AND DISPOSAL**

- Avoid or minimize breaking the AC pipe.
- Double-wrap large pieces in 1000-gauge polythene sheeting. Seal with duct tape.
- Attach asbestos warning stickers "DANGER ASBESTOS-CONTAINING MATERIAL".
- Place small pieces in the asbestos waste container.
- Locate a landfill that is authorized to accept asbestos waste

**7. MARKING OF AC PIPE ABOVE GROUND**

Given the dangerous nature of AC pipes there is a significant health risk for workers and the public if these pipes are uncovered and damaged or cut accidentally, or deliberately to conduct the necessary work by other utility service providers e.g. gas supply, electricity line, telephone line. To warn the other utility service providers about the potential risk associated with disturbing the AC pipes which will be left in situ, proper marking should be provided above ground. The detail of marking is shown below.

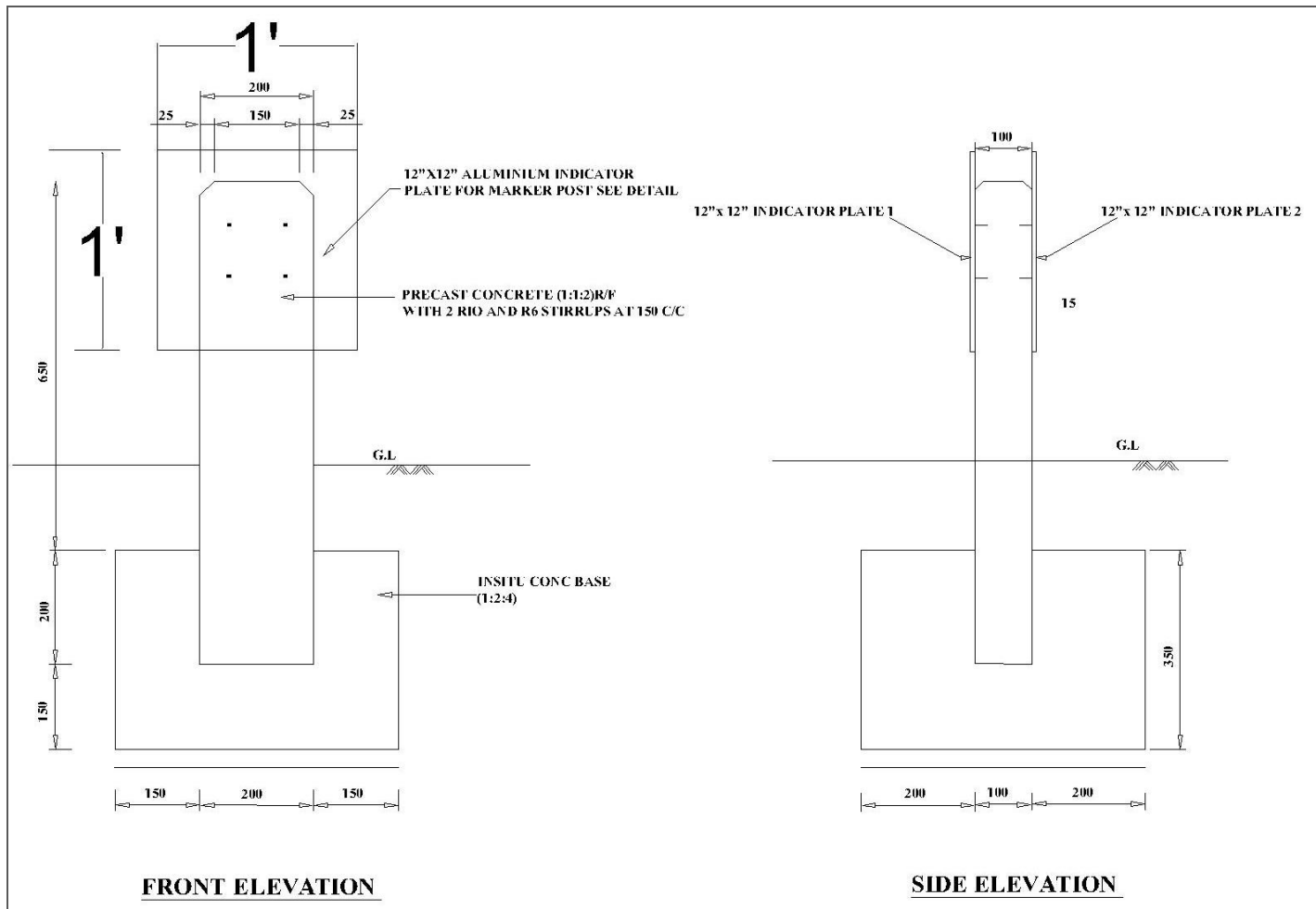

**Indicator Plate 1**

Asbestos Cement pipe is just below this sign and is harmful to health if disturbed.

Please ensure that no damage occurs by nails, screws or hole drilling etc.

Report to DWASA if any damage occurs.

**Indicator Plate 2**